

MODEL FQ CABLE SUSPENDED FLOAT SENSOR

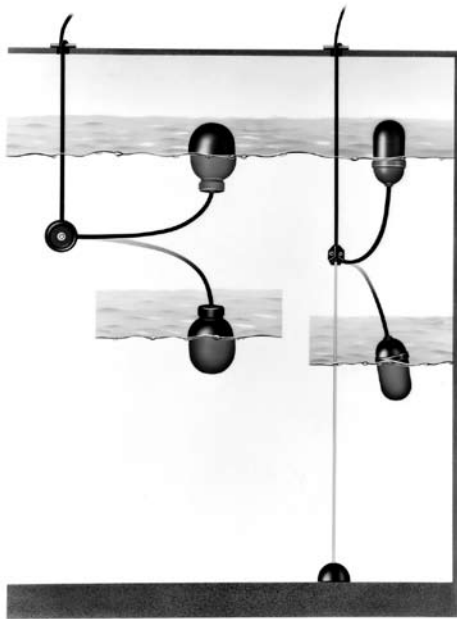

Features

- One float gives a latched signal between two different levels
- Differential and switch level points are easily field adjustable
- Unique “tumbling” action eliminates chatter
- Works in dirty liquids
- Reliability/Long switch life
- Easy installation

General Description

The FQ-6 and FQ-8 cable suspended float sensors are designed to provide the control signals for a differential pump control system. These top mounting sensors are suitable for use in a wide variety of open tanks or vessels. The control differential in the FQ-6 is adjustable from 270mm to 1000mm and FQ-8 is adjustable from 330mm to 4000mm. The ABS covered float and the PVC cable make them ideal for most pump control applications.

A number of float units can be used together to give multiple level switch points in one flanged holder. Each float can be easily assembled on site and the switch operating points are adjusted by altering the length of the cable.

Operational Description

The Model FQ contains a hermetically sealed reed switch, a permanent magnet, and a movable weight.

As the liquid level rises and falls, the movable magnetized weight slides up and down inside the float and acts upon an encapsulated reed switch. The float tumbles at its upper and lower limits. In this way the reed switch changes state at the upper limit and remains in this state until the lower limit is reached and it changes state again.

Chemical Resistance

The ABS covered float and PVC cable are compatible with a wide range of liquids. However, there are some liquids that may damage these materials.

ABS can be quickly damaged by the following liquids:

- Aromatics (benzene, toluene, xylene) cause the float to dissolve.
 - Esters and ketones cause the float to swell.
- PVC cable can be used with the following cautions:
- Oils, especially vegetable oils and fats, tend to absorb the plasticizer of PVC cable. Consequently the cable stiffens.

If necessary, alternative Hypalon cable is available with FQ-8. In general, the resistibility depends on concentration, duration of immersion, presence of suspended solids and/or corrosive gasses and temperature. Although these cable suspended floats are designed for long life, we recommend that they are replaced at adequate intervals.

Technical Note

To avoid personal injury and protect the switch for electrical surges, connect the float to our relay unit model RE7000 or similar devices.

Specifications

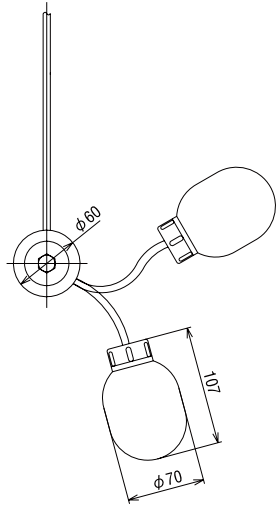
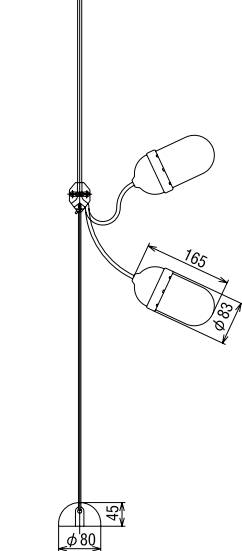
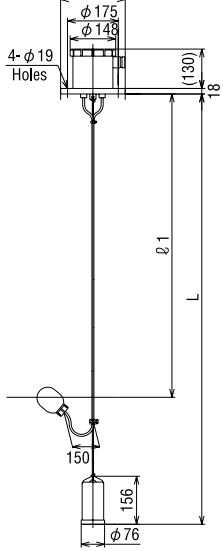
Model	FQ-6	FQ-8	FQ66/FQ88	
Drawing				
Operating Temperature*1	-10°C to 50°C			
Maximum Pressure	200kPa / 2bar			
Minimum S.G.	0.7	0.9		
Cable Length	6 meter (Max. 20 meter)			
Life Expectancy	1 × 10 ⁵ Operations			
Material	Cable	φ 6.5, PVC	φ 8.1, PVC	
	Float	PP (ABS for float cap)	ABS	
	Housing		ABS	
	Flange		PVC	
	Weight	Gray iron casting (Black painting)		3kg, PVC (build in steel)
	Rope			PE
Mounting			JIS10K100A (4 holes)	
Cable Entry			JIS F 20a (G3/4)	
Protection			IP45*2	
Maximum Detection Points			6	

*1 FQ-8T (High Temp. Version) is available up to 70°C.

*2 IP65 is optionally available.

Contact Rating

Max. Capacity	AC	50VA
	DC	50W
Max. Current	AC	0.5A
	DC	0.5A
Max. Voltage	AC	300V
	DC	300V

Switch Action

Up ON: FQ-6, FQ-8, FQ-8T

Down ON: FQ-6B, FQ-8B

Minimum setting point

Model	Min. ℓ 1		Min. ℓ ~ ℓ	Min. L ~ ℓ n	
	↑ ON, OFF	↓ ON, OFF		↑ ON, OFF	↓ ON, OFF
FQ66	187mm	457mm	480mm	327mm	57mm
FQ88	165mm	495mm	570mm	465mm	135mm