

I N S T R U C T I O N M A N U A L
F O R

C A P A C I T I V E L E V E L S E N S O R

M O D E L : K R V



Issued Sep. 03, 2003



NOHKEN INC.

MUST BE READ BEFORE USING





- This manual is for standard specifications. Read the other manuals for explosion-proof specifications.
- This manual describes the handling, inspection and adjustment of the sensor. Read and understand this manual before installation.
- Any documents and/or directions from Nohken and the agents aside from this manual shall be preceded.
- Save this manual to refer when you need.
- If you have any questions or comments about this manual and/or the sensor, ask Nohken's sales office.

Signal words in this manual means as follows:



 CAUTION	Indicates an potentially hazardous situation which, if not avoided, may result in minor or moderate injury.
 NOTE	Indicates exceptional cases and attention for handling of sensors.

	Indicates prohibition. The explanation with this manual should always be followed.
	Indicates directions. The explanation with this manual should always be followed.





▲ CAUTIONS

<ul style="list-style-type: none">• Since this sensor is not an explosion-proof construction, do not use where flammable gas, explosive gas or the vapor exists. Otherwise, explosion of the gases and/or the vapor may cause serious disasters. Use explosion-proof sensors in hazard areas.	
<ul style="list-style-type: none">• Do not modify or disassemble the sensor. Otherwise, the sensor may be damaged.	
<ul style="list-style-type: none">• Turn off the power immediately if there is bad smell and/or the strange sound. Do not use until the remedy is administrated.	
<ul style="list-style-type: none">• Make sure that the wiring is correct. Otherwise, the sensor may be damaged, ignited or cause an electric shock.	
<ul style="list-style-type: none">• Turn off the power when sensor is checked or wired. Otherwise, damage or electrical accident may happen.	

▲ NOTES

<ul style="list-style-type: none">• Do not give strong shocks to the sensor. Dropping, throwing, striking and dragging the sensor, for example, are to cause strong shocks and damage the sensor.	
<ul style="list-style-type: none">• The specifications such as ambient temperature, maximum voltage and the power rating shall meet the conditions. Otherwise, the sensor may cause malfunction, damage, ignition, electric shock and injury. Read and check the clause of specification in the manual or specification sheets.	
<ul style="list-style-type: none">• Operating test shall be conducted before practical use. If malfunction occurs and the accident is predicted, the remedy shall be administrated by using another sensor with different operating principle in parallel.	

▲ NOTES

<ul style="list-style-type: none">• Check the chemical compatibility with the material you want to use.	
<ul style="list-style-type: none">• When carrying, installing and removing the sensor, hold the flange or the plug part. Otherwise, the flange or the plug may drop off from the housing and be damaged.	
<ul style="list-style-type: none">• <u>The sensor which is 50cm or longer</u> Do not leave the sensor upright, but lay it down on the floor. Otherwise, the sensor and/or the surrounding things may be damaged or get injured if the sensor falls.	
<ul style="list-style-type: none">• To prevent from electric shocks such as lightning and the static electricity, provide conductor or the surge absorber. Otherwise, the sensor may cause malfunction, damage, ignition, electric shock and injury.	
<ul style="list-style-type: none">• <u>When connecting inductive load or the lamp load to the relay output contact.</u> To prevent overvoltage and overcurrent, provide a protective circuit to the load. Otherwise, the contact may be damaged.	

INTRODUCTION

- A. This manual specifies standard specifications of this product. Some specifications may be different from your product if you order the custom-made product.
- B. A variety of specifications are available to meet your process conditions, such as installation conditions, chemical compatibility, and so on. We are glad to offer suggestions to assist your decision.
- C. If you have any questions or comments for the contents of this manual, ask Nohken's sales office written on the front cover.
- D. Nohken Inc. pursues a policy of continuing improvement in design and performance of this product. We will supply the alternative parts or complete new products required to repair or replacement.
- E. Specifications are subject to change without any obligation on the part of the manufacturer.

WARRANTY & DISCLAIMER

- A. Nohken Inc. warrants this product against defects in design, material and workmanship for a period of 1 (one) year from the date of original factory shipment.
- B. If defects occurs during the above-mentioned warranty period, Nohken will, at its option, replace or recondition the product without charge. This shall constitute the exclusive remedy for breach of warranty.
- C. Nohken Inc. makes no warranty with respect to:
 - C-a Failure not to comply with instructions of this manual.
 - C-b Failure or damage due to improper installation, wiring, operation, maintenance, inspection and storing.
 - C-c Product which has been in any way repaired, altered or tampered with by others.
 - C-d Product repaired or modified by using undesignated parts, subassemblies and materials.
 - C-e Direct incidental or consequential damages or losses or expenses resulting from any defective product or the use of any product.
 - C-f Objective of the sensor is clearly specified in chapter 1, PURPOSE OF USE.
 - C-g Inevitable accident such as acts of God, force majeure, radioactive contamination and so on.

THIS WARRANTY IS IN LIEU OF AND EXCLUDES ALL OTHER WARRANTIES OF MERCHANTABILITY OR FITNESS FOR A PARTICULAR PURPOSE.

NOTE TO USERS

It is essential for the user to read this manual carefully before installing the KRV capacitive level sensors to ensure proper operation.

TABLE OF CONTENTS

MUST BE READ BEFORE USING	
INTRODUCTION	
WARRANTY & DISCLAIMER	
NOTE TO USERS	
TABLE OF CONTENTS	
1. PURPOSE OF USE	Page 1
2. STANDARD SPECIFICATIONS	Page 1
2.1 Model and Suffix Code	Page 1
2.2 Standard Specifications	Page 2
3. PRINCIPLE OF OPERATION	Page 2
4. INSTALLATION	Page 3
4.1 Horizontal Installation	Page 3
4.2 Vertical Installation	Page 3
5. WIRING	Page 4
6. ADJUSTMENT PROCEDURES	Page 4
6.1 Initial Tuning	Page 4
6.2 Sensitivity Adjustment	Page 5
6.3 On Delay Timer	Page 6
7. PRECAUTIONS	Page 6
8. MAINTENANCE	Page 7
9. TROUBLESHOOTING	Page 7

1. PURPOSE OF USE

This is a level sensor utilizing a high-frequency wave. It detects the level of various types of liquid and powder, and permits detection of the boundary of two different liquid, the sediment in liquid, and the level in a high temperature high-pressure vessel, which was impossible in the past.

A special circuit is employed in the amplifier circuit, eliminating malfunctions and troubles such as adhesion of material to the electrode and damage in the semiconductors caused by high-pressure static electricity generated in powder.

The detector inserted into a tank uses no movable part. This structure makes the unit durable and reliable for a long period of time.

2. STANDARD SPECIFICATIONS

2.1 Model and Suffix Code

KRV-□□□H

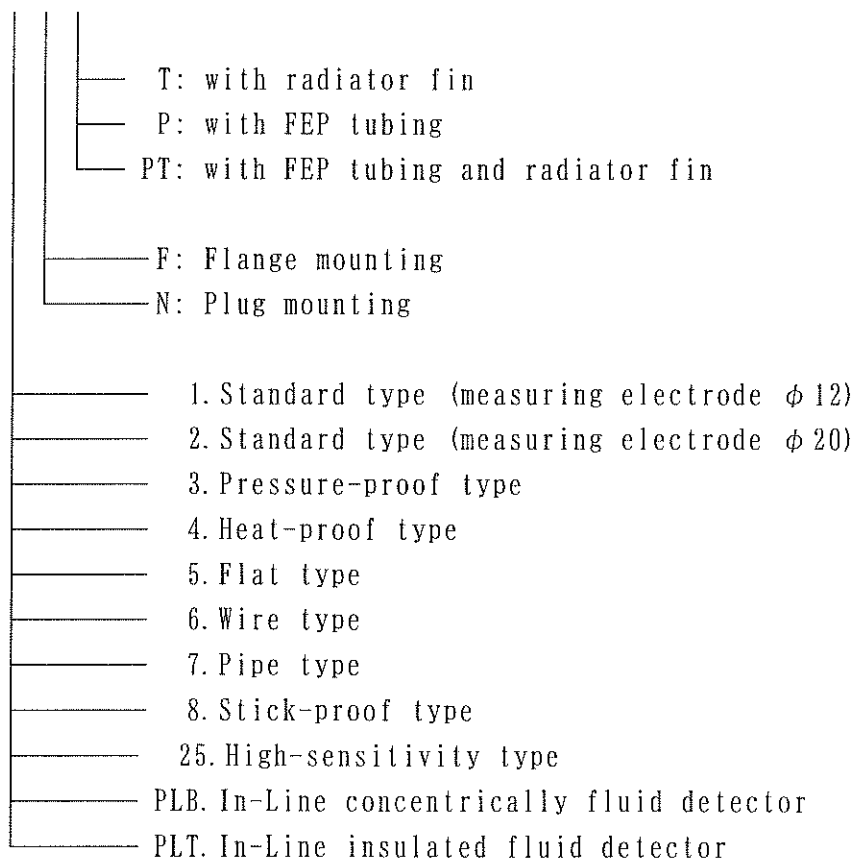

NOTES

- Code - T : Not applied to code 3 and 4.
- Code - P and - PT : For Flange mounting type only.
- Code - PLB and -PLT : Not appeared mounting codes.

2. 2 Standard Specifications

2. 2. 1 Sensitivity : A 0. 5 pF or more
(selectable) B1 3 pF or more
B2 5 pF or more
C 200 pF or more
D 4000 pF or more
2. 2. 2 Operation indication : LED lighting (Red)
2. 2. 3 Power supply : 100 to 120 V AC \pm 10 % 50/60 Hz
200 to 240 V AC \pm 10 % 50/60 Hz
2. 2. 4 Power consumption : Approx. 2. 5 VA
2. 2. 5 Output : Relay contact (1 SPDT)
Delay time is possible to set between 0. 5 and 10 seconds.
2. 2. 6 Contact rating : 250 V 3 A AC (resistive load)
30 V 3 A DC (resistive load)
2. 2. 7 Insulation resistance: 100 M Ω or more (500 V DC)
2. 2. 8 Withstand voltage : 1500 V AC for a minute
2. 2. 9 Withstand pressure : 1 MPa Max. for code 1, 2, 5 and 25
3 MPa Max. for code 3 and 4
500 kPa Max. for code 6
100 kPa Max. for code 7, 8, 2FP and 2FPT
2. 2. 10 Vibration proof : 10 to 55 Hz (Amplitude 1. 5 mm)
2. 2. 11 Working temperatures: Amp. unit: -10 to +55 $^{\circ}$ C
Electrode: -20 to +60 $^{\circ}$ C
(-20 to +180 $^{\circ}$ C heat-proof type)
2. 2. 12 Working humidity : 85 % RH Max.
2. 2. 13 Construction : IP 65

3. PRINCIPLE OF OPERATION

When this level sensor is set on a tank, a condenser is formed between the detector electrode and the tank inside wall. The capacitance of this condenser varies proportional to the specific inductivity of the material put in the tank. This change in capacitance is detected, whereby liquid or powder level is detected.

※ Specific inductivity

Capacitance when nothing is in a tank : C_0

Capacitance when material is put in a tank and its level reaches the detection electrode : C_1

$$\epsilon s = \frac{C_1}{C_0}$$

The " ϵs " is called a specific inductivity, a constant determined by the kind of material to detect.

Therefore, the detection sensitivity of this level sensor is determined by the specific inductivity " ϵs " of material to detect.

4. INSTALLATION

The level sensor is installable horizontally or vertically.

4. 1 Horizontal installation

The electrode is parallel to the level fluctuating surface of the detecting material in this installation. Even a slight change in the material level can be exactly detected, since an electrode area ratio is taken large for this change and a large capacity change is obtained. However, this is unsuitable for viscous materials. Such material easily adheres to the electrode, spoiling stability.

4. 2 Vertical installation

The problem of adhering to the electrode is less and the operation is stable. However, as the electrode area ratio is small for a change in material level, the detection accuracy is lowered and the electrode size needs to be long for detection of the lower limit of a tank.

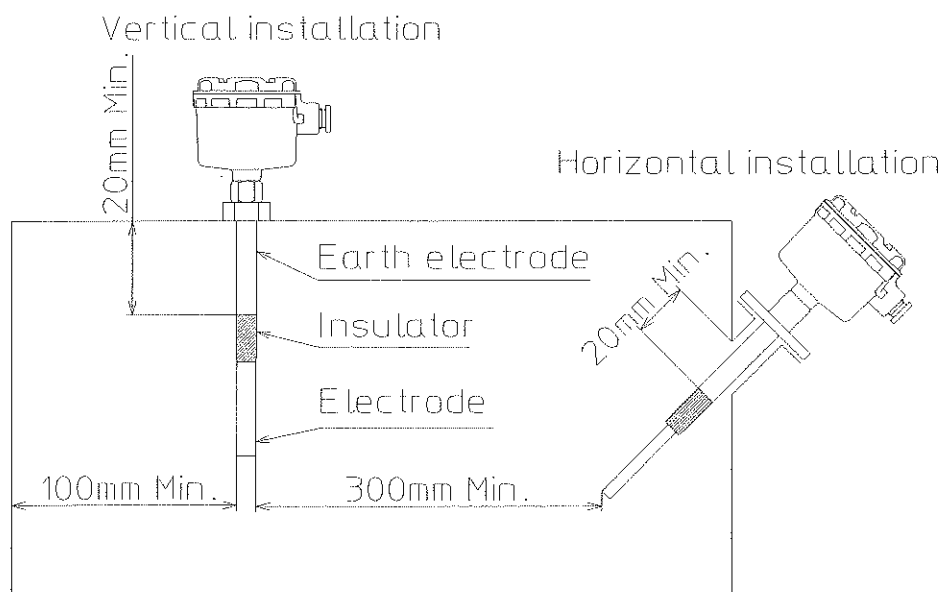
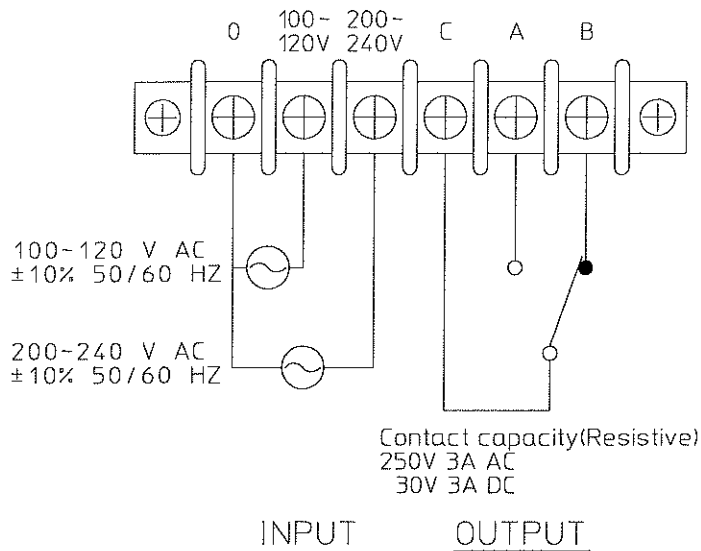

Fig. 1 Example of installation

- ※ In the horizontal installation, we recommend to set the level sensor obliquely so that the electrode is directed as downward as possible. This minimizes material stacking on or adhering to the electrode.
- ※ When a nozzle neck is used, set it so that the earth electrode is inserted into a tank 20mm or more. This prevents the electrode from being affected by the material adhered to the tank inside wall or adhesions.

5. WIRING

Avoiding faulty wiring (for instance, feeding 200 V AC to the 100 V AC terminal), connect the input power and output contacts properly according to the following Fig. 2



- Recommended cable
1.25 mm², four-core cable
(CVV, CVS or equivalent)
- Cable inlet (G 1/2)
- Applicable crimp terminal
R-1.25-3 or equivalent

Fig. 2

6. ADJUSTMENT PROCEDURES

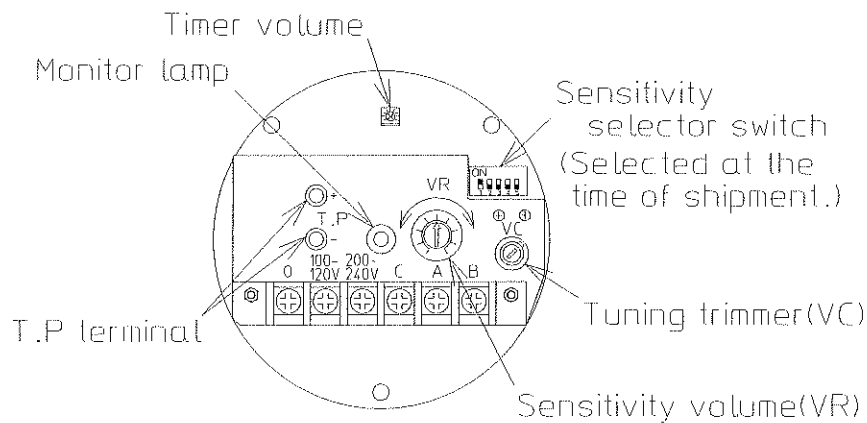

Fig. 3

Reference :

Try not to change the sensitivity selector switch, because the selection of sensitivity range with the sensitivity selector switch may be impossible when the electrode length is different from the standard (L-250mm).

6. 1 Initial tuning

- 6.1.1 Marking sure there is nothing inside, set the sensor on the tank reserved for measuring.
- 6.1.2 Ascertain that the power supply is turned on.
- 6.1.3 Push the positive (+) rod into the red side of the T.P terminal; likewise, the negative (-) rod into the black side. Use an analog tester with a voltage range of 5-10 V DC and an internal resistance of over 20 k Ω .
- 6.1.4 Set the sensitivity volume at midpoint, as shown in Fig.4 , and then turn the tuning trimmer slowly with a small screwdriver.
The voltage will describe the secondary curves shown in Fig.5.
The point (the lowest one) where the voltage drops to the bottom and then climbs upward represents the correct tuning point.
If difficulty should be experienced in proper tuning when this reading on the tester approaches 0 V DC, repeat the adjustment by moving the sensitivity volume clockwise to 4-5 V DC. As shown in Fig.5, tuning points will describe secondary curves A, B, and C when the sensitivity volume is turned.

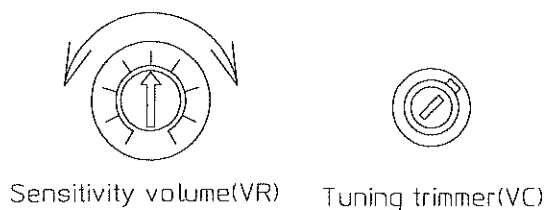

Fig. 4

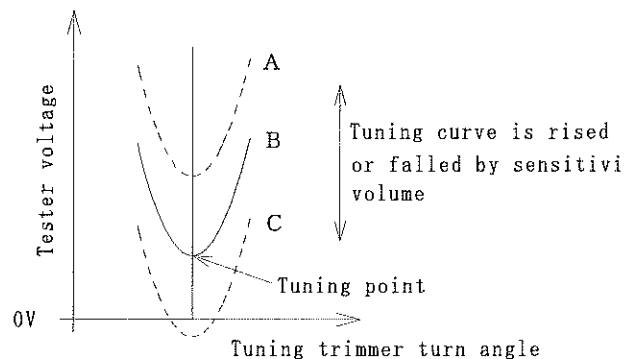

Fig. 5

- 6.1.5 Once the turning point is properly set, freeze all adjustments and proceed to the next chapter 6.2 Sensitivity adjustment.

6. 2 Sensitivity adjustment

When the measuring material is available:

- 6.2.1 Feed the measuring material into the tank till the moment the electrode is hidden under the measuring material.
- 6.2.2 Turn the sensitivity volume either clockwise or counterclockwise until the reading on the tester registers a voltage of approximately 8 V DC or higher. (The voltage reading on the tester climbs when the sensitivity volume turned clockwise; it falls when turned counterclockwise.)

- 6.2.3 Empty the tank (or the detection material does not reach the electrode tip.) and then drop the reading on the tester to 1 V DC or less. After ascertaining this reading, which ends adjustment, remove the rods of the tester. Whenever the reading fails to reach below 1 V DC, carry out the following tasks.
- 6.2.4 Turn the sensitivity volume counterclockwise until the reading on the tester registers approximately 1 V DC.
- 6.2.5 Feed the measuring material, once again, into the tank until the electrode hides under the measuring material, and then ascertain that the monitor lamp is ON and also that the voltage reading on the tester registers at least 5.5V DC. As adjustments are now ended, remove the rods of the tester. (In case this repetition also fails, please consult us at once since the predetermined sensitivity of the amplifier unit might not be compatible with the material to be measured.

Simplified method of adjustment when the measuring material is not available:

Turn the sensitivity volume either clockwise or counterclockwise until the tester registers a voltage of 1 V DC. (the voltage reading on the tester climbs when the sensitivity volume turned clockwise; it falls when turned counterclockwise.) After ascertaining this reading, which ends adjustment, remove the tester rods. Follow the above procedure under chapter 6.2 Sensitivity adjustment for subsequent measurement.

6.3 ON Delay Timer

To avoid the relay chattered when actuating, adjust the delay time to be desired. The range is from 0.5 to 10 seconds. The Relay status LED will follow the delay time.

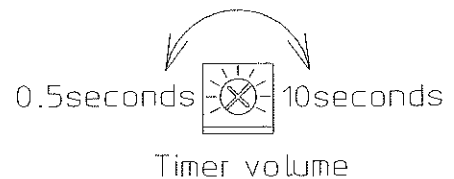

Fig. 6

7. PRECAUTIONS

The sensor and the amplifier in each of our level sensors as well as the sensitivity of detection have been preset to match the capacitance (dielectric constant) and/or the resistance of the measuring material. Please consult us if you need to replace any material.

8. MAINTENANCE

- 8.1 In case material for measurement is likely to adhere to the electrode more than other substances, pull out the sensor at regular intervals to free the electrode from contaminants and keep it clean.
- 8.2 In case environmental conditions (ambient temperature and humidity, amongst others) should change to a considerable extent, readjust the amplifier unit before actual operation in order to avoid malfunctioning of the level sensor.

9. TROUBLESHOOTING

CAUTION

Use the following chart to troubleshoot the malfunctioning sensor.
If your remedies are unsuccessful, ask Nohken for repair and replacement.

- 9.1 Relay de-energized when electrode is covered by materials
- Sensitivity set too low Perform adjusts according to chapter 6. ADJUSTMENT PROCEDURES.
 - Material has bridge or angle Change mounting position with angle of repose considered.
 - Improper output connections Recheck wiring with reference to Fig. 2 connection diagram under chapter 5. WIRING.
- 9.2 Relay energized when electrode is not covered by materials
- Tuning is wrong Perform adjusts according to chapter 6. ADJUSTMENT PROCEDURES.
 - Sensitivity set too high Perform adjustments according to chapter 6. ADJUSTMENT PROCEDURES.
 - Material has dead stock Instal level sensor to better position where generation of dead stock not possible.
 - Improper output connections Recheck wiring with reference to Fig. 2 connection diagram under chapter 5. WIRING.
 - Faulty electrode insulation Trace and remove defect and repeat adjustments according to chapter 6. ADJUSTMENT PROCEDURES.

NOHKEN INC.

HEAD OFFICE : 15-29,Hiroshiba-cho,Suita-city,Osaka 564-0052,Japan.
TEL:06-6386-8141 FAX:06-6386-8140

TOKYO BRANCH OFFICE : 67,Kandasakumagashi,Chiyoda-ku,Tokyo 101-0026,Japan.
TEL:03-5835-3311 FAX:03-5835-3316

NAGOYA OFFICE : 3-10-17,Uchiyama,Chikusa-ku,Nagoya-city,Aichi 464-0075,Japan.
TEL:052-731-5751 FAX:052-731-5780

KYUSHU OFFICE : 14-1,2-chome,Asano,Kokurakita-ku,Kitakyushu-city,Fukuoka 802-0001,Japan.
TEL:093-521-9830 FAX:093-521-9834