

I N S T R U C T I O N M A N U A L
F O R
V I B R A T I N G L E V E L S E N S O R

M O D E L : V M 3 1
 V M 3 2



Issued Sep. 24, 1999



NOHKEN INC.

MUST BE READ BEFORE USING

- This manual is for standard specifications. Read the other manuals for explosion-proof specifications.
- This manual describes the handling, inspection and adjustment of the sensor. Read and understand this manual before installation.
- Any documents and/or directions from Nohken and the agents aside from this manual shall be preceded.
- Save this manual to refer when you need.
- If you have any questions or comments about this manual and/or the sensor, ask Nohken's sales office.

Signal words in this manual means as follows:

 CAUTION	Indicates an potentially hazardous situation which, if not avoided, may result in minor or moderate injury.
 NOTE	Indicates exceptional cases and attention for handling of sensors.

	Indicates prohibition. The explanation with this manual should always be followed.
	Indicates directions. The explanation with this manual should always be followed.

▲ CAUTIONS

• Since this sensor is not an explosion-proof construction, do not use where flammable gas, explosive gas or the vapor exists. Otherwise, explosion the gases and/or the vapor may cause serious disasters.



• Do not modify or disassemble the sensor. Otherwise, the sensor may be damaged,



• Operating test shall be conducted before practical use. If malfunction occurs and the accident is predicted, the remedy shall be administrated by using another sensor with different operating principle in parallel.



• To prevent from electric shocks such as lightning and the static electricity, provide conductor or the surge absorber. Otherwise, the sensor may cause malfunction, damage, ignition, electric shock and injury.



• When connecting inductive load or the lamp load to the relay output contact.



To prevent overvoltage and overcurrent, provide a protective circuit to the load. Otherwise, the contact may be damaged.

▲ NOTES

• Do not give strong shocks to the sensor. Dropping, throwing, striking and dragging the sensor, for example, are to cause strong shocks and damage the sensor.



• The specifications such as ambient temperature, maximum voltage and the power rating shall meet the conditions. Otherwise, the sensor may cause malfunction, damage, ignition, electric shock and injury. Read and check the clause of specification in the manual or specification sheets.



• Operating test shall be conducted before practical use. If malfunction occurs and the accident is predicted, the remedy shall be administrated by using another sensor with different operating principle in parallel.



⚠ NOTES

- Check the chemical compatibility with the material you want to use.



- Earth terminal shall be grounded JIS Class D ground (earth resistance maximum 100 Ω).
Otherwise, the electric shock may occur.



- To prevent from electric shocks such as lightning and the static electricity, provide conductor or the surge absorber. Otherwise, the sensor may cause malfunction, damage, ignition, electric shock and injury.



- When connecting inductive load or the lamp load to the relay output contact.

To prevent overvoltage and overcurrent, provide a protective circuit to the load. Otherwise, the contact may be damaged.



INTRODUCTION

- A. This manual specifies standard specifications of this product. Some specifications may be different from your product if you order the custom-made product.
- B. A variety of specifications are available to meet your process conditions, such as installation conditions, chemical compatibility, and so on. We are glad to offer suggestions to assist your decision.
- C. If you have any questions or comments for the contents of this manual, ask Nohken's sales office written on the front cover.
- D. Nohken Inc. pursues a policy of continuing improvement in design and performance of this product. We will supply the alternative parts or complete new products required to repair or replacement.
- E. Specifications are subject to change without any obligation on the part of the manufacturer.

WARRANTY & DISCLAIMER

- A. Nohken Inc. warrants this product against defects in design, material and workmanship for a period of 1 (one) year from the date of original factory shipment.
- B. If defects occurs during the above-mentioned warranty period, Nohken will, at its option, replace or recondition the product without charge. This shall constitute the exclusive remedy for breach of warranty.
- C. Nohken Inc. makes no warranty with respect to:
 - C-a Failure not to comply with instructions of this manual.
 - C-b Failure or damage due to improper installation, wiring, operation, maintenance, inspection and storing.
 - C-c Product which has been in any way repaired, altered or tampered with by others.
 - C-d Product repaired or modified by using undesignated parts, subassemblies and materials.
 - C-e Direct incidental or consequential damages or losses or expenses resulting from any defective product or the use of any product.
 - C-f Objective of the sensor is clearly specified in chapter 1, PURPOSE OF USE.
 - C-g Inevitable accident such as acts of God, force majeure, radioactive contamination and so on.

THIS WARRANTY IS IN LIEU OF AND EXCLUDES ALL OTHER WARRANTIES OF MERCHANTABILITY OR FITNESS FOR A PARTICULAR PURPOSE.

MUST BE READ BEFORE USING

INTRODUCTION

WARRANTY & DISCLAIMER

TABLE OF CONTENTS

1. PURPOSE OF USE	1
2. SPECIFICATIONS	1
2.1 Model and Suffix Code	1
2.2 Standard Specifications	1
2.3 Dimensions	2
2.4 Component names	3
3. PRINCIPLE OF OPERATION	4
4. INSTALLATIONS	5
4.1 Unpacking	5
4.2 Installation Location	5
4.3 Installation	6
5. WIRING	8
6. ADJUSTMENTS	9
6.1 Power detecting sensitivity	9
6.2 Adjusting the detecting sensitivity	10
6.3 High/Low file-safe mode	12
7. MAINTENANCE/INSPECTION	12
7.1 Inspection	12
7.2 Maintenance	13
8. TROUBLESHOOTING	14

1. PURPOSE OF USE

The vibrating level sensor, model VM31,32 types are made specifically for solid level measurement in containers. They are designed for bulk density as low as 0.2g/cm³. The model VM is usable in a wide range of specifications.

As the powder detecting point is at the tip of the detection rod, there's no malfunctions by adherence on the bin wall inside.

2. SPECIFICATIONS

2. 1 Model and Suffix Code

Table 2-1

VM	Vibrating level sensor	
	Code	Power supply
	31	90 to 132 V AC 50/60 Hz
	32	180 to 264 V AC 50/60 Hz

2. 2 Standard Specifications

- (1) TYPE : Vibrating level sensor
- (2) MODEL : VM31,VM32 series
- (3) MEASURING OBJECT : Powder, Granular materials, Pellets.
- (4) OPERATION CHARACTERISTICS
 - (a) Detecting sensitivity : Bulk density as low as (loose)0.2g/cm³
 - (b) Operation indication : Indication of relay output: red LED
 - (c) Measuring frequency : Approx. 500 Hz
- (5) ELECTRIC CHARACTERISTICS:
 - (a) Power supply : VM31 90~132V AC 50/60Hz
VM32 180~264V AC 50/60Hz
 - (b) Power consumption : Less than 2.5VA
 - (c) Output : Relay contact 1 SPDT
Switching delay time:Turn-on , approx. 3 sec.
Turn-off, approx. 3 sec.
 - (d) Contact rating : 240V 3A AC (Resistive load)
30V 3A DC (Resistive load)
 - (e) Withstand voltage : 1500V AC for one minute
Between housing and each terminal except ground terminal
 - (f) Insulation resistance : 500V DC More than 100MΩ
Between housing and each terminal except ground terminal

(6) MECHANICAL CHARACTERISTICS:

- (a) Working pressure : 1 MPa
- (b) Concentrated load : Horizontal 0.12 kN Max.
Vertical 0.23 kN Max.
(at the tip of the detection rod)

(7) SURROUNDING CONDITIONS:

- (a) Working temperature : Detecting part -20~+80°C, Housing -20~+60°C
(Get rid of dew.)

- (b) Working humidity : 5 to 85% Rh

(8) CONSTRUCTION : Detecting part IP68
Housing IP65

(9) PHYSICAL:

- (a) Materials : Detecting part : Stainless steel, Brass, Silicon rubber
: Housing : Aluminum die casting
(Silver hammerton coating.)
- (b) Mounting : G 3/4 (Screw thread)
- (c) Cable inlet : JIS F 20a (G 3/4)
- (d) Mass : Approx. 1.1 kg

2.3 Dimensions

【See Fig. 2-1】

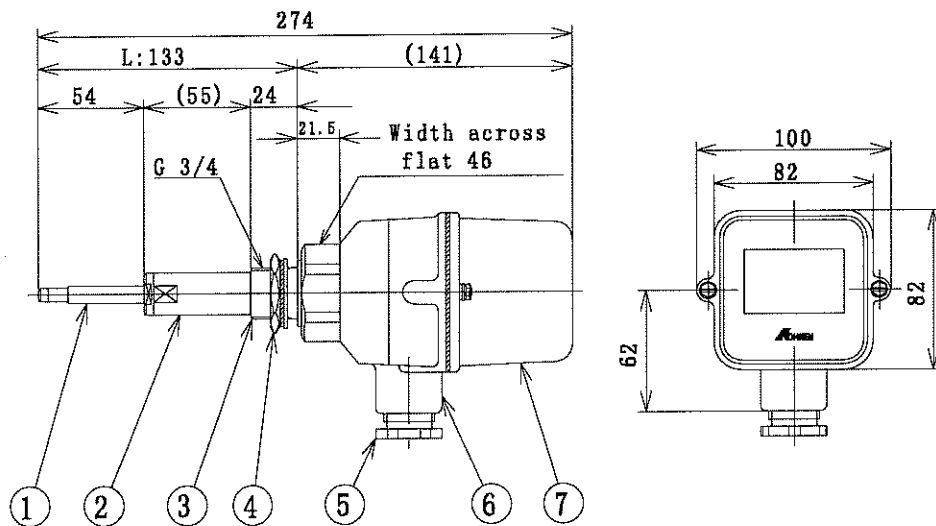

Fig. 2-1

2. 4 Component names 【See Fig. 2-1, Fig. 2-2】

- ① DETECTION ROD
Detecting part which touches directly to the powders. It vibrates when there's no powders, but vibration will dampen or stop when it becomes buried in the measured materials.
- ② EXTENSION PIPE
Sensor measuring length extension part.
- ③ SCREW
Screw to install the sensor to the bin.
- ④ NUT
Nut to install the sensor to the bin.
- ⑤ CABLE GLAND
Cable entry to enter the cable.
- ⑥ HOUSING
Electronic circuit is placed.
- ⑦ COVER
Cover for the sensor.
- ⑧ GROUND TERMINAL
Ground terminal shall be grounded.
- ⑨ SENSITIVITY SETTING SWITCH
To set the sensor detecting sensitivities or to check the operating condition.
- ⑩ TERMINALS
Output terminal for power connection and sensor relay contact signal.
- ⑪ FAIL-SAFE MODE SETTING SWITCH
To set the sensor detecting sensitivity mode and to check the operating condition.
- ⑫ ALARM INDICATOR
Red lamp lights when the sensor energizes the relay.
- ⑬ TEST POINT 1
The point for checking the voltage to be applied to receiving element.
- ⑭ TEST POINT 2
The point for performance check and fine adjustment of sensitivity:
【Test point 2(⑭) for positive (+) point and Ground terminal(⑧) for negative (-) point.】
- ⑮ SENSITIVITY SETTING VOLUME
To set the sensor detecting sensitivities and to check the operating condition.
- ⑯ TEST POINT 3
The point for checking the voltage to be applied to exciting element.

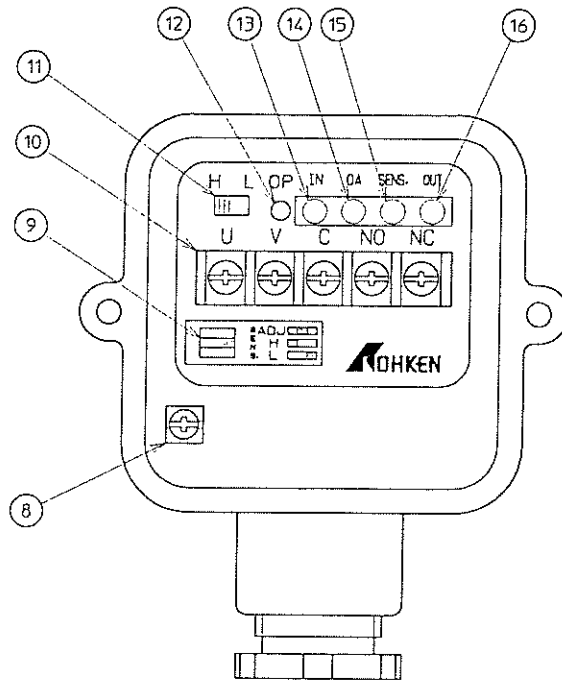

Fig. 2-2

3. PRINCIPLE OF OPERATION

The detection rod vibrates by installing piezo-electric element and acceleration pick-up mounted detection rod at the tip of the internal detection rod. The piezo-electric element provides vibration and the acceleration pick-up detect damps in the vibrational amplitude. Covered with solids dampens vibration of the detection rod. The electronic circuit detects the damping of these vibration and converts into the relay output.

【See Fig. 3-1】

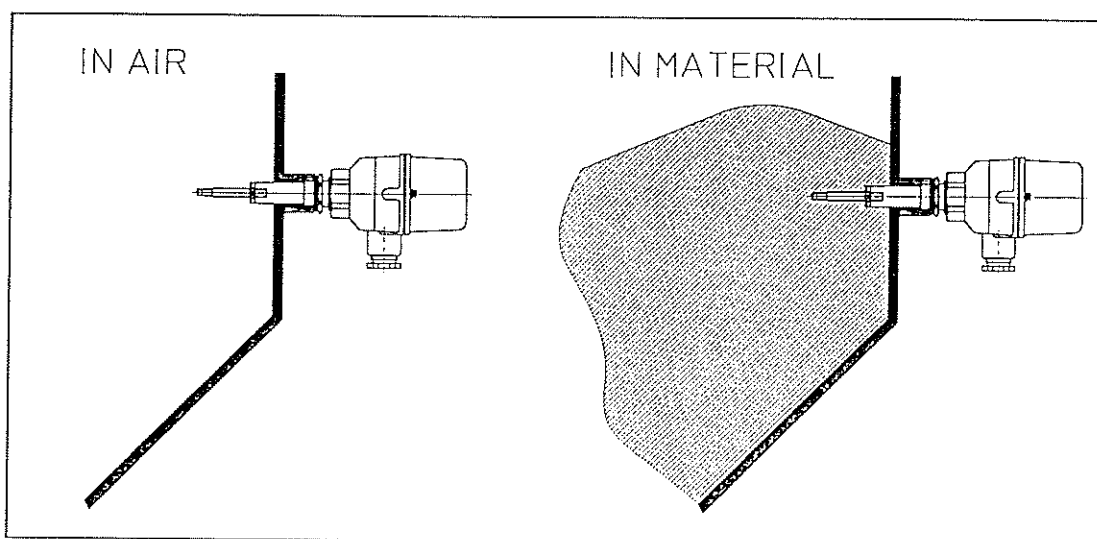

Fig. 3-1

4. INSTALLATIONS

4.1 Unpacking

This unit has been thoroughly inspected and carefully packed at the factory to prevent from damage during shipment. When unpacking, care must be taken not to damage the instrument with mechanical shock. After unpacking, visually check the instrument exterior for damage.

4.2 Installation Location

This sensor should be installed in an area which meets the following conditions:

- (1) Provide ample space for maintenance/inspection.
- (2) Do not install the sensor where the temperature is high.

The highest allowance temperature for detecting part (the part which goes into the bin) is 80℃. Housing's (the part out of bin) highest allowance temperature is 60℃. Higher than these temperatures are not suitable for the sensors to be installed.

- (3) Do not install the sensor where it gets direct sunlights.【See Fig. 4-1】

△ CAUTION

Install a sun shield over the housing if exposed to direct sunlights.

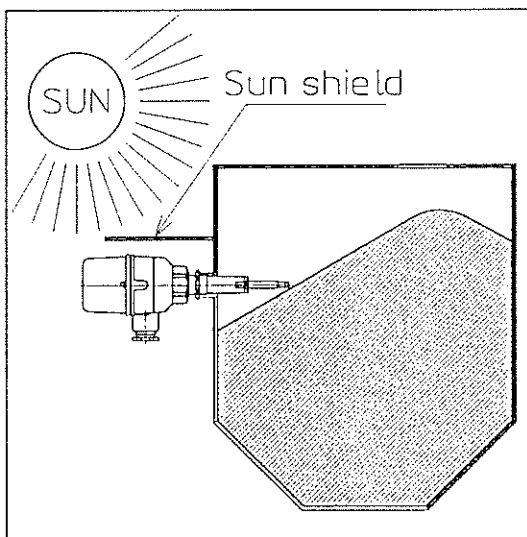

Fig. 4-1

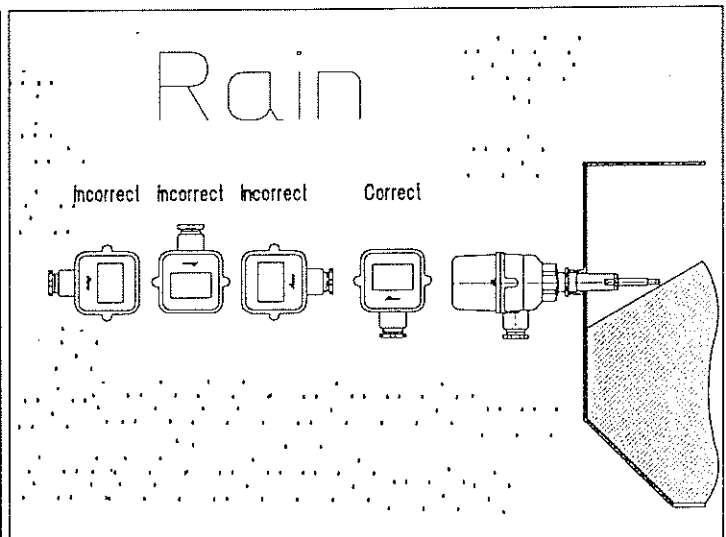
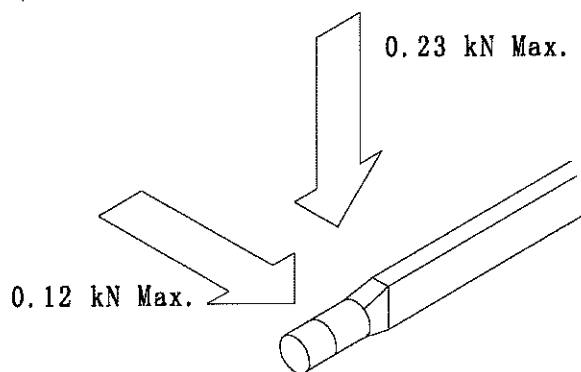

Fig. 4-2

- (4) Dew withstanding.
Do not install in the place where ambient temperature rapidly drop (for example, 40°C to 0°C). Otherwise, it may cause dew and damage the sensor.
- (5) Be attentive for the splash of waterdrops (rainwater) to the housing.
The housing protection is IP54. The cable gland and cover must be properly fitted to protect the sensor from rain, splashing water, etc. When side-mounting, make sure the cable gland is pointing down to the ground to prevent from the rain to intrude.【See Fig. 4-2】
- (6) Do not install the sensor where corrosive gases occur.
Most of the amplifier electronic inside the housing may corrode by the corrosive gases (such as NH_3 , SO_2 , CO_2 , etc.). Do not install in a place like this or it may cause malfunction.
- (7) Vibration is low.
Do not install the sensor near vibrator or knocker where intensive vibration or shock occur. It may cause malfunction or the sensor will be damaged.
- (8) Non-hazardous area.
Model VM cannot be used in an explosive atmosphere.

4. 3 I n s t a l l a t i o n

- (1) For model VM, there is threaded type to install in the container wall.
- (2) Installing directions are horizontal mounting. Install the way it fits detecting levels.
- (3) Model VM can not be installed in any directions. The cable gland shall be installed pointing down to the ground.
- (4) The maximum load at the tip of the detection rod is 0.12 kN(Horizontal) or 0.23 kN(Vertical). If it exceeds, the detection rod will be bent. Install the guard at least 10cm above the detecting rod if necessary. 【See Fig. 4-3】



F i g . 4 - 3

- (5) The sensor will detect the dead stock despite there aren't any measuring materials. 【See Fig. 4-4】
- (6) When used as a high level control, calculate the angle of repose for measuring materials and install the detection rod where it surely covers. 【See Fig. 4-5】

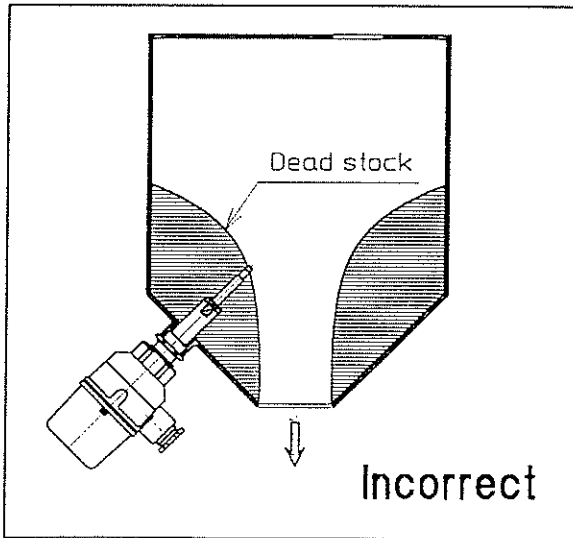

Fig. 4-4

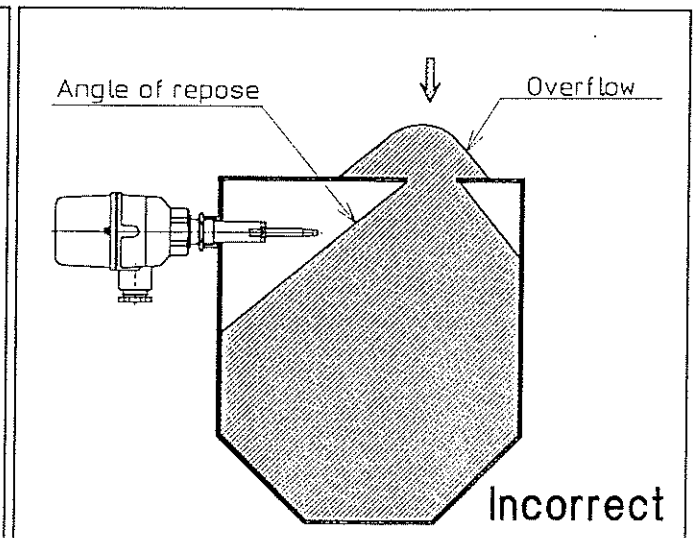

Fig. 4-5

- (7) When used as a low level control, install the guard above the detection rod as bridge or overload is anticipated.
- (8) The detection rod shall not contact with bin wall.
The detection rod will not vibrate despite there aren't any measuring materials. 【See Fig. 4-6】
- (9) Keep the detection rod out of the direct flow.
Failure to do this may damage the sensor. Install the guard at least 10cm above the detection rod if necessary. 【See Fig. 4-7】

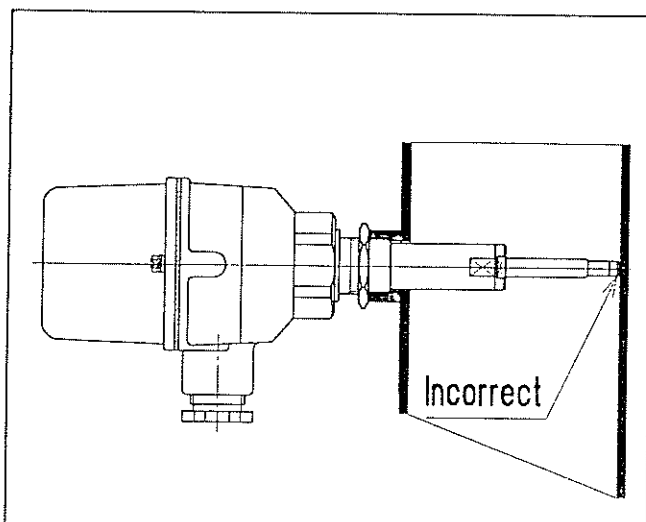

Fig. 4-6

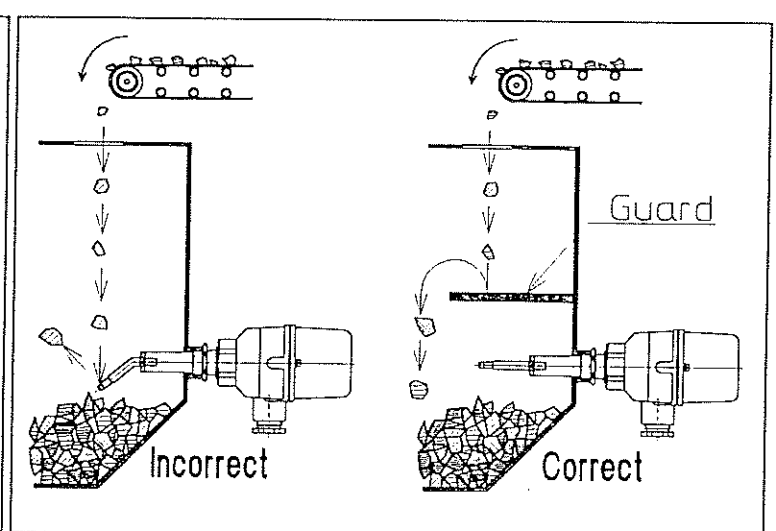

Fig. 4-7

5. WIRING

Proceed as follows:

- (1) Make sure the cable entry is pointing down to the ground.
- (2) Remove the housing cover.
- (3) Remove approximately 100mm (3.94 inch) of cable sheath from the end of the cable and approximately 10mm (0.39 inch) of conductor sheath.
- (4) Bring cables into the housing.

Recommended cable is as follow:

Table 5-1

Cable dimension	Cross section area of conductor	Notes	
		Cable gland	Terminal
$\phi 11 \sim \phi 11.9$	More than 0.75mm^2	G 3/4	M3.5

▲ CAUTION

Tighten the cable gland to prevent from rain, splashing water, etc.

- (5) Connect lead wires to the terminal.

- (a) Connect the power supply.

This vibrator type sensor has no power switch and fuse. If necessary install it separately. Recommended fuse is 250V, 0.5A Max.

- If 90~132V AC is used, ensure model and suffix codes is VM31.
Connect the power supplying line to **U** terminal and **V** terminal.
- If 180~264V AC is used, ensure model and suffix codes is VM32.
Connect the power supplying line to **U** terminal and **V** terminal.

- (b) Connecting relay contact signal output terminal.

See the table below:

Table 5-2

Terminals	No material on detection rod	Material covering detection rod
NO and C	Open	Closed
NC and C	Closed	Open

▲ CAUTION

The maximum relay contact is 240V AC 3A/30V DC 3A (resistive load).
Do not connect overload. When load capacity is more than maximum contact, connect external relays between load and sensor's output terminal.

NOTE:

In case the power failure (blackout etc.) occurs, between C terminal and NO terminal will be de-energized and between C terminal and NC terminal will be energized.

(6) Ensure that there is no miswiring.

▲ CAUTION

Make sure the supplying voltage and the terminal written on P.C. board matches. Wrong voltage or miswiring will damage the sensor.

▲ WARNING

Ground terminal shall be grounded. If not, you will get an electrical shock.

(7) Re-install and tighten the cover.

6. ADJUSTMENTS

Fundamentally, the model VM needs no adjustments. But adjust the detecting sensitivity for:

- fine powders.
- highly fluidized powders.
- sticky and build-up materials.
- improper adjustment

6.1 Power detecting sensitivity

The adjustment of the detecting sensitivity depends on bulk density, fluidity, build-up·concentrate features and so on. Accordingly, the data written below will be nearly general.

Polycarbonate pellet (PC pellet), salt, powdered coffee's detecting sensitivities are written below for your reference.【See Fig. 6-1】

Table 6-1

Powder names	Bulk density	Detecting level	
		High sensitivity	Low sensitivity
Salt	1.4	More than 25mm	More than 30mm
PC pellet	0.7	More than 25mm	More than 35mm
Micro cell	0.26	More than 35mm	Undetectable

Low sensitivity : The sensitivity when shipping.

Bulk density more than 0.5.

High sensitivity: The most high detecting sensitivity.

Bulk density between 0.2 and 0.5.

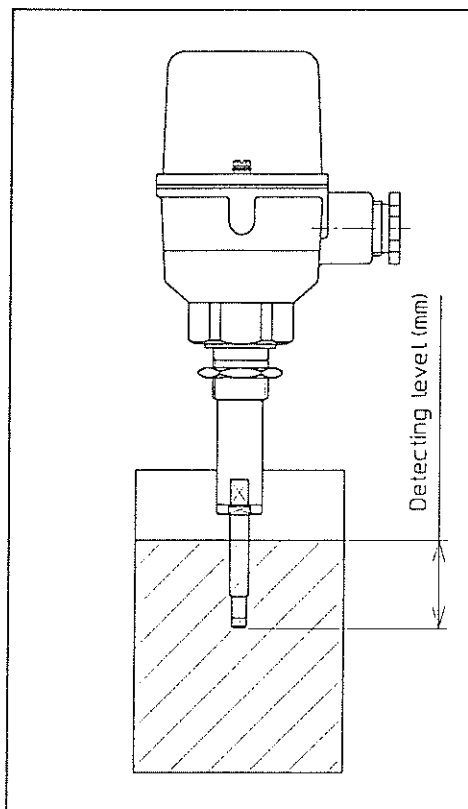

Fig. 6-1

6.2 Adjusting the detecting sensitivity

Proceed as follows and 【See Fig. 6-2, Fig. 6-3】:

- (1) Prepare the following equipment.
 - (a) 0-10V AC range tester. (In case of voltmeter, input resistive more than 10K Ω .)
 - (b) Small-sized slotted blade screw driver.
- (2) Clean up the detection rod. While adjusting, make sure the measuring materials are not contacting the detection rod. If it contacts, exact adjustment will be impossible.
- (3) Turn on the power supply if it is not on.
- (4) Wait for 5 seconds.
- (5) Set the sensitivity setting switch to ADJ (middle point).
- (6) Plug in the positive reed to TEST POINT 2 (⑭) and negative reed to GROUND TERMINAL (⑧). Adjust the tester to voltage range which can

detect the direct current 0~10V every 0.5V.

Table 6-2

Sensitivity	Setting voltage (at ADJ side)	Position of sensitivity setting switch after calibration
High	more than 8 V DC	ADJ → H
Low	more than 8 V DC	ADJ → L

(a) Standard (shipping) sensitivity.【Low sensitivity】

Adjust the TEST POINT 2 voltage to more than 8 V by sensitivity setting volume. Set the sensitivity setting switch to L. (bulk density more than 0.5)

(b) High sensitivity for fine powder and material too fluid.

Adjust the TEST POINT 2 voltage to more than 8 V by sensitivity setting switch to H. (bulk density between 0.2 and 0.5)

Ask NOHKEN for repair or replacement in case of indicating the incorrect voltage.

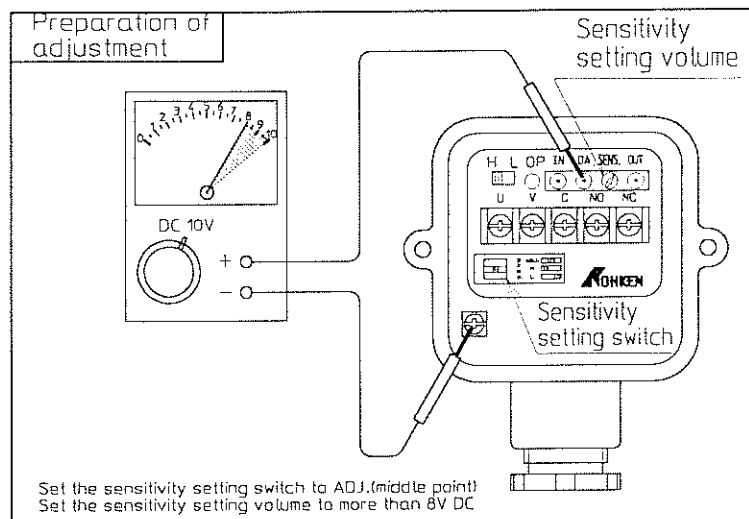

Fig. 6-2

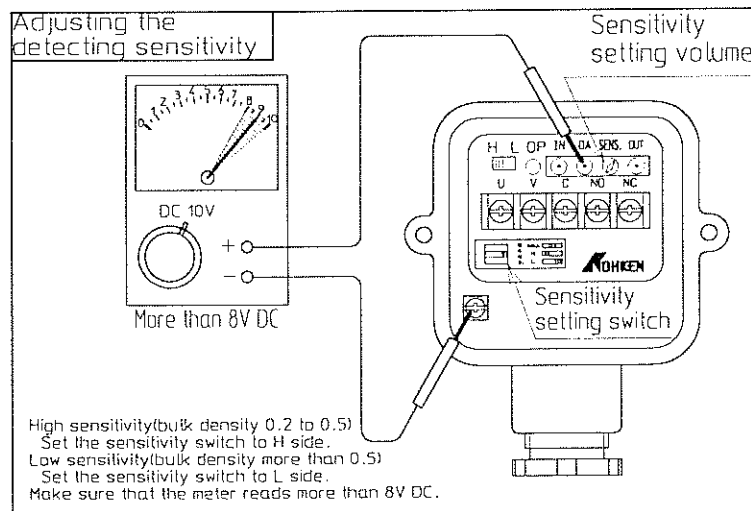

Fig. 6-3

6.3 High/Low fail-safe mode

High level fail-safe mode(H.ON) means that the output relay is de-energized when the detection rod is not covered by descending material or upon power loss. Low level fail-safe mode(L.ON) means that the output relay is de-energized when the detection rod is covered by rising material or upon power loss.

By changing the fail-safe switch, the two connections can be switched from High/Low fail-safe mode.【See Fig. 6-4】

	Fail-safe mode	RELAY LAMP	Relay Contact
	H. ON		C — O- NO ●- NC
	L. ON		C — O- NO ●- NC
	H. ON		C — O- NO ●- NC
	L. ON		C — O- NO ●- NC
POWER OFF			C — O- NO ●- NC

Fig. 6-4

7. MAINTENANCE & INSPECTION

In general, the sensitivity properly set VM needs no maintenance. But in order to use the sensor stable for a long time, maintenance and inspection is needed in periodic intervals.

7.1 Inspection

Inspection is held to examine

- if the sensitivity is set to proper sensitivity.
- if it is affected by the build-up.
- if the sensor is operating correctly.

Proceed as follows:

- (1) Make sure the measuring materials are not touching the detection rod.
Replace the sensor out of the bin if necessary.
- (2) Supply power to the sensor.

- (3) Make sure which the sensor sensitivity was set, high, standard (shipping sensitivity).
- (4) Prepare the 0 ~ 10 V DC range voltmeter.
- (5) Plug in the positive reed to the TEST POINT 2 (⑭) and negative reed to the GROUND TERMINAL (⑧) .
- (6) See the table below. Ensure both (L or H) and (AJ.) stated voltage can be read for each set sensitivity. 【 See the Table 7-1 below 】

Table 7-1

Set sensitivity	Position for sensitivity setting switch and voltage reading	
	(L or H)	AJ.
Standard	H: 8~9V DC	ADJ: more than 8 V DC
Low	L: 8~9V DC	ADJ: more than 8 V DC

- (7) If the voltage reading is accomplished, the sensitivity adjustment is correct. Nevertheless malfunction occurs, see section 8 for trouble shooting.
- (8) If the voltage reading is low, clean up the build-up on the detection rod. Then adjust the sensitivity volume in the state of sensitivity setting switch is ADJ until the correct voltage can be read. Nevertheless unsuccessful, the sensor is defective. Ask NOHKEN for repair/replacement.
- (9) If the voltage reading is high, the sensitivity adjustment is not proper. Adjust the sensitivity volume in the state of sensitivity setting switch is **ADJ** until the correct voltage can be read. Nevertheless unsuccessful, the sensor is defective. Ask NOHKEN for repair/replacement.

7. 2 Maintenance

In order to use model VL for a long time, maintenance is needed in periodic intervals.

【 Maintenance method is as follows 】

- (1) A large amount of build-up on the tip of the detection rod will cause wrong signal output. Clean build-up in periodic intervals in case of measuring strong adherence materials.
- (2) Make sure the raindrops (water-drops) are not intruding inside the housing. In case of the outdoor use, the water-drops will intrude easily if the housing cover or the cable entry is loose. Intrude of the water-drops will cause an erroneous signals, so please make sure to tighten in an periodic intervals.
- (3) According to the measuring materials, the sensor will cause corrosion or

rubbing. Make sure the corrosion and rubbing are not outbreaking or progressing in periodic intervals.

8. TROUBLESHOOTING

Use the following chart to troubleshoot a malfunctioning sensor.

【 See the Table 8-1 below 】

Table 8-1

Problems	Possible causes	Remedies
Not detecting powders. (It overflow.)	Powder bulk density is too small. Bulk density under 0.2 cannot be detected.	Set high sensitivity.
	Power supply not connected.	Connect the power.
	Material too fluid.	Set high sensitivity.
	Effected by heavy hopper vibration.	Set high sensitivity or install the sensor in better location.
It keeps detecting powders. (Hopper was empty and the materials ran out.)	Material has bridge or an angle of repose.	Install sensor in better location.
	Heavy deposit on detection rod. Material has dead stock.	Clean detection rod. Install sensor in better location or isolate dead stock.

If above remedies are unsuccessful, ask NOHKEN for repair and replacement.

NOHKEN INC.

HEAD OFFICE : 15-29, Hiroshiba-cho, Suita-city, Osaka 564-0052, Japan.

TEL:06-6386-8141 FAX:06-6386-8140

TOKYO BRANCH OFFICE : 67, Kandasakumagashi, Chiyoda-ku, Tokyo 101-0026, Japan.

TEL:03-5835-3311 FAX:03-5835-3316

NAGOYA OFFICE : 3-10-17, Uchiyama, Chikusa-ku, Nagoya-city, Aichi 464-0075, Japan.

TEL:052-731-5751 FAX:052-731-5780

KYUSHU OFFICE : 14-1, 2-chome, Asano, Kokurakita-ku, Kitakyushu-city, Fukuoka 802-0001, Japan.

TEL:093-521-9830 FAX:093-521-9834