

# I N S T R U C T I O N   M A N U A L

F O R

Q U I C K   F L O A T   T Y P E   L E V E L   S E N S O R



M O D E L :   F   Q



---

## Read and understand this manual for safely usage.

- This manual describes the product of standard specification. Read the other manual for the product of explosion-proof specification.
- This manual describes the handling, inspection and adjustment of the product which model is mentioned on cover page. Read and understand this manual before handling.
- Follow the additional document and/or direction, submitted by NOHKEN INC. and our distributor or agent, even if the terms are mentioned in this manual.
- Save this manual in proper place being available to refer immediately.
- The specification of product mentioned in this manual may not be satisfied by the condition of environment and usage. Check and consider carefully before using.
- Contact to sales office at NOHKEN INC. for any question or comment about this manual and product.

The followings are the description of the terms in this manual.

 <b>WARNING</b>	Indicates a potentially hazardous situation which, if not pay attention, could result in death, serious injury or serious disaster.
 <b>CAUTION</b>	Indicates a hazardous situation which, if not pay attention, may result in minor or moderate injury or damage to device.

	Indicates prohibited matter. The explanation with this mark shall be followed
	Indicates instructed matter. The explanation with this mark shall be followed.

 **WARNING**

This product is not explosion-proof construction. Do not install this product to the place where the flammable gas or vapor is occurred.

If installed, the flammable gas or vapor may be ignited, and serious disaster may be occurred. Use the product of explosion-proof construction in this case.



Do not modify or disassemble the product. Otherwise, the product and connected device may be malfunctioned, damaged, fired, or miner injury and electric shock may be occurred. (Follow the additional document and/or direction, submitted by NOHKEN INC. and our distributor or agent.)



Turn off the power, before wiring and inspection. Otherwise, electric leakage, fire caused by short circuit, and electric shock may be occurred.



Ensure the wire is properly connected. The product and connected device may be malfunctioned, damaged, fired, or miner injury and electric shock may be occurred by improper wiring.



Turn off the power immediately, if the smoke, strange smell and sound are occurred.

Do not use it until the problem is solved.



 **CAUTION**

Avoid strong shock and rough handling to this product. The product may be damaged by strong shock as dropping, falling, throwing, knocking, lugging, and etc.



Follow the specification of operating temperature, operating pressure, switch rating, and etc. Otherwise, the product and connected device may be malfunctioned, damaged, fired, or miner injury and electric shock may be occurred. Check the manual or specification sheet.



Operation test shall be done before practical usage. If the serious accident is expected to occur by malfunction of product, the other operating principle of product shall be installed in parallel.





## CAUTION

Check and deeply consider the chemical compatibility for material of product in advance. The part especially float, which is very thin, may be malfunctioned by miner corrosion.



Check and deeply consider the chemical compatibility for material of product in advance.



Hold the stem very close to mounting point, when carrying, installing, and removing. If hold the terminal box, it may be taken off from the flange or plug, and the product may be damaged by dropping.



The product is 50cm or longer

The product shall be kept in horizontally. The product and other goods be damaged, and miner injury may be occurred by falling.



Earth terminal shall be grounded to JIS Class D ground (earth resistance less than 100Ω). If not grounded, electric shock may occurred by any accident.



Provide arrester or surge absorber to avoid electrical impact such as lightning and static electricity. If not provide, the product and connected device May be malfunctioned, damaged, and fired, or miner injury and electric shock may be occurred.



In case of connecting inductive or lamp load to the product.  
Provide protective circuit to the load to avoid over voltage and over current. If not provide, the contact may be damaged.



# INTRODUCTION

- A) This manual specifies the specification of general product. If you order special product, some details of specification may be different with the manual.
- B) We are glad to suggest and advice for Model selection and chemical resistant of material, but final decision has to be made by the customer.
- C) This manual has prepared with close attention. Ask sales office at NOHKEN INC. for any question or comment about the contents of this manual.
- D) For replacement parts  
The quality of product has frequently improved, so same spare part may not be supplied. In this case, replacement part or product may be supplied. Ask sales office at NOHKEN INC. for details.
- E) The contents of this manual are subject to change any time without notice due to the improvement of product.

# WARRANTY & DISCLAIMER

- A) NOHKEN INC. warrants this product against defect in design, material and workmanship for a period of 1(one) year from the date of original factory shipment.
- B) The warranty only covers the damage of products. The secondary and third kind disasters are not covered by NOHKEN INC.
- C) NOHKEN INC. shall not be liable for the following.
  - C-a) Do not follow the description and direction in this manual.
  - C-b) Damage due to improper installation, wiring, usage, maintenance, inspection, storing, and etc.
  - C-c) Repair and modification are done by the person who is not employee of NOHKEN INC. and our distributor or agent.
  - C-d) Improper parts are used and replaced.
  - C-e) The damage is occurred by the device or machine except our products.
  - C-f) Improper usage. (See "Proper of usage" in chapter 1 in this manual)
  - C-g) Force Majeure including, but not limited to, fire, earthquake, tsunami, lightning, riots, revolution, war, radioactive pollution, acts of God, acts of government or governmental authorities, compliance with law, regulation, and order.

THE TERMS OF WARRANTY AND DISCLAIMER SHALL IN NO WAY LIMIT YOUR REGAL LIGHT.

# TABLE OF CONTENTS

	<u>Page No.</u>
1. PURPOSE OF USE . . . . .	1
2. SPECIFICATIONS . . . . .	1
2.1 Model . . . . .	1
2.2 Standard Specifications . . . . .	1
2.3 Outline drawing . . . . .	2
3. OPERATING PRINCIPLE . . . . .	3
4. COMPONENT NAMES . . . . .	4
4.1 External parts . . . . .	4
4.2 Terminal box internal parts . . . . .	4
5. INSTALLATION . . . . .	4
5.1 Unpacking . . . . .	4
5.2 Assembly . . . . .	5
5.3 Installation location . . . . .	7
5.4 Installation method . . . . .	7
6. WIRING . . . . .	8
6.1 Model RE relay unit . . . . .	8
7. TECHNICAL NOTES . . . . .	9
8. MAINTENANCE / INSPECTION . . . . .	9
9. TROUBLE SHOOTING . . . . .	10

# 1. PURPOSE OF USE

The Quick Float Model FQ series designed for level detection of sewage, waste water and high viscosity of liquid as slurry, used a reed switch.

# 2. SPECIFICATIONS

## 2.1 Model

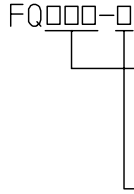

NOTE : In case of a part of sensor, model are FQ-6, FQ-8 or FQ-8T.

## 2.2 Standard specification

Table 1

Model		FQ66	FQ88	FQ88T
Contact rating	Max. contact rating	50 VA , 50 W		
	Max. working current	0.5 A AC, 0.5 A DC		
	Max. working voltage	300 V AC, 300 V DC		
Mechanical characteristics	Float withstand pressure	200 kPa Max.		
	Allowable impact	100 m/s <sup>2</sup>	500 m/s <sup>2</sup>	
	Buoyancy of float	Approx. 1.3 N	Approx. 1.2 N	
Operation characteristics	Control width ※1	0.27 to 1 m	0.33 to 4 m	
	Specific gravity	0.7 or more	0.9 or more	
	Life expectancy	2 × 10 <sup>5</sup> times or more. (When the cable is bent 180 degrees.)		
Working temperature		-10 to +50 °C		-10 to +70 °C
Construction		IP 45		
Materials	Terminal box	ABS		
	Flange	PVC		
	Float	PP (Float cap : ABS)	ABS	
	Cable	PVC sheath		
	Anchor weight	PVC (Built-in Steel Structure)		
	Rope	PE	PP(Core: Glassfiber)	
	Rope clip	PVC		
Others	Installation	Flange connection (JIS 10K 100A or equivalent, proviso 4 holes)		
	Cable inlet	G 3/4 or equivalent		

※1 Reference with Fig. 12.

### 2.3 Outline drawing

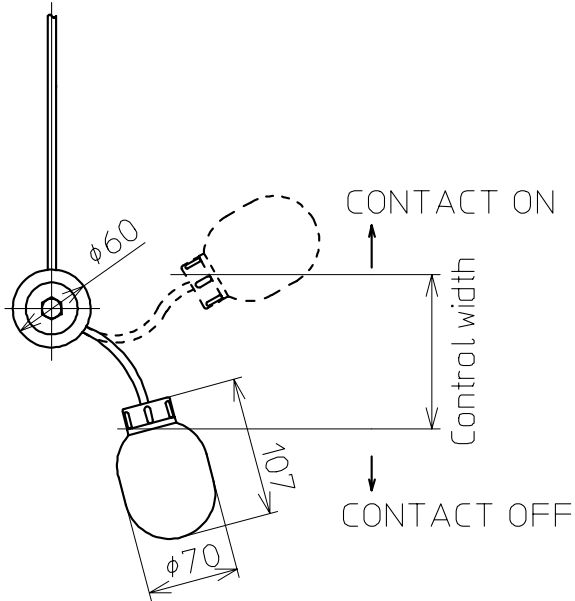

Fig. 1 Model FQ-6

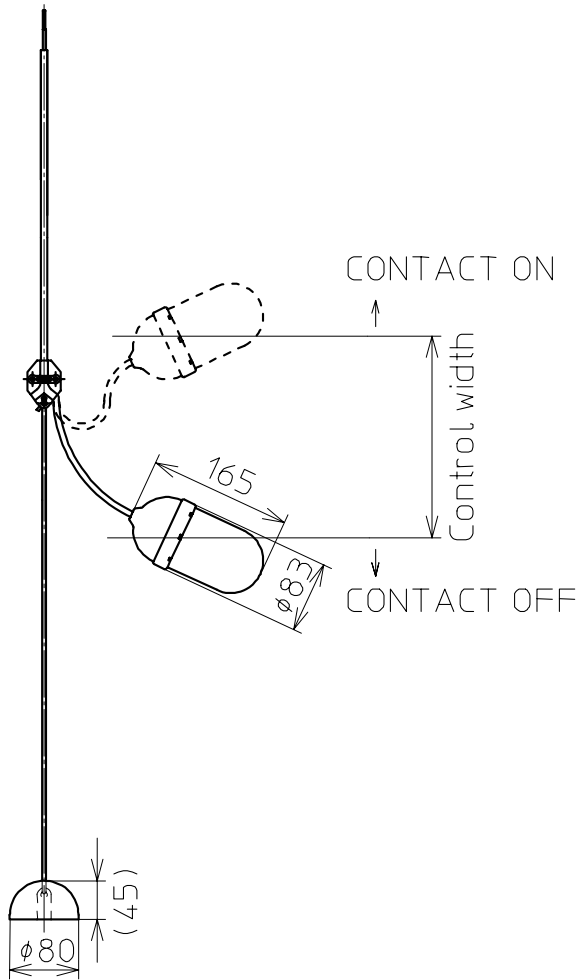

Fig. 2 Model FQ-8 & FQ-8T

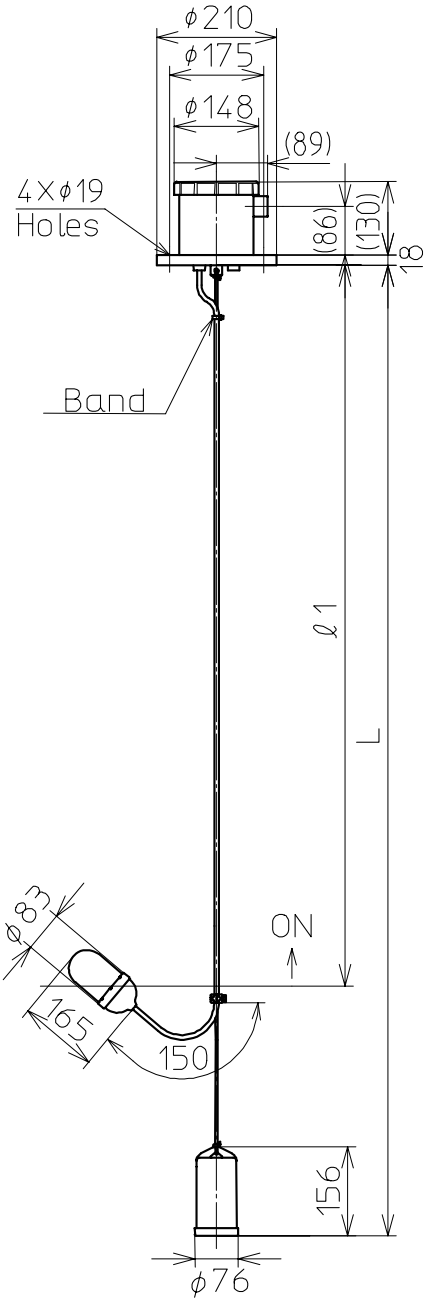

Fig. 3 Model FQ88-1



### 3. OPERATING PRINCIPLE

In case of rising level, the float rises according to liquid level as shown Fig. 4(1) and turns over quickly on upper limit level of control width. Movable weight travels from top to bottom inside the float and touch with permanent magnet. Magnetized movable weight make reed switch actuate.

In case of falling level also, the float turns over quickly on lower limit of control width. Movable weight travels from bottom to top inside the float and separates from permanent magnet. The reed switch loses magnetic field and stops actuation.

The level switch is not affected chattering of liquid such as movable weight travels on only both limits of control. Having a function of holding as the explanation described above allow feed water control or waste water control.

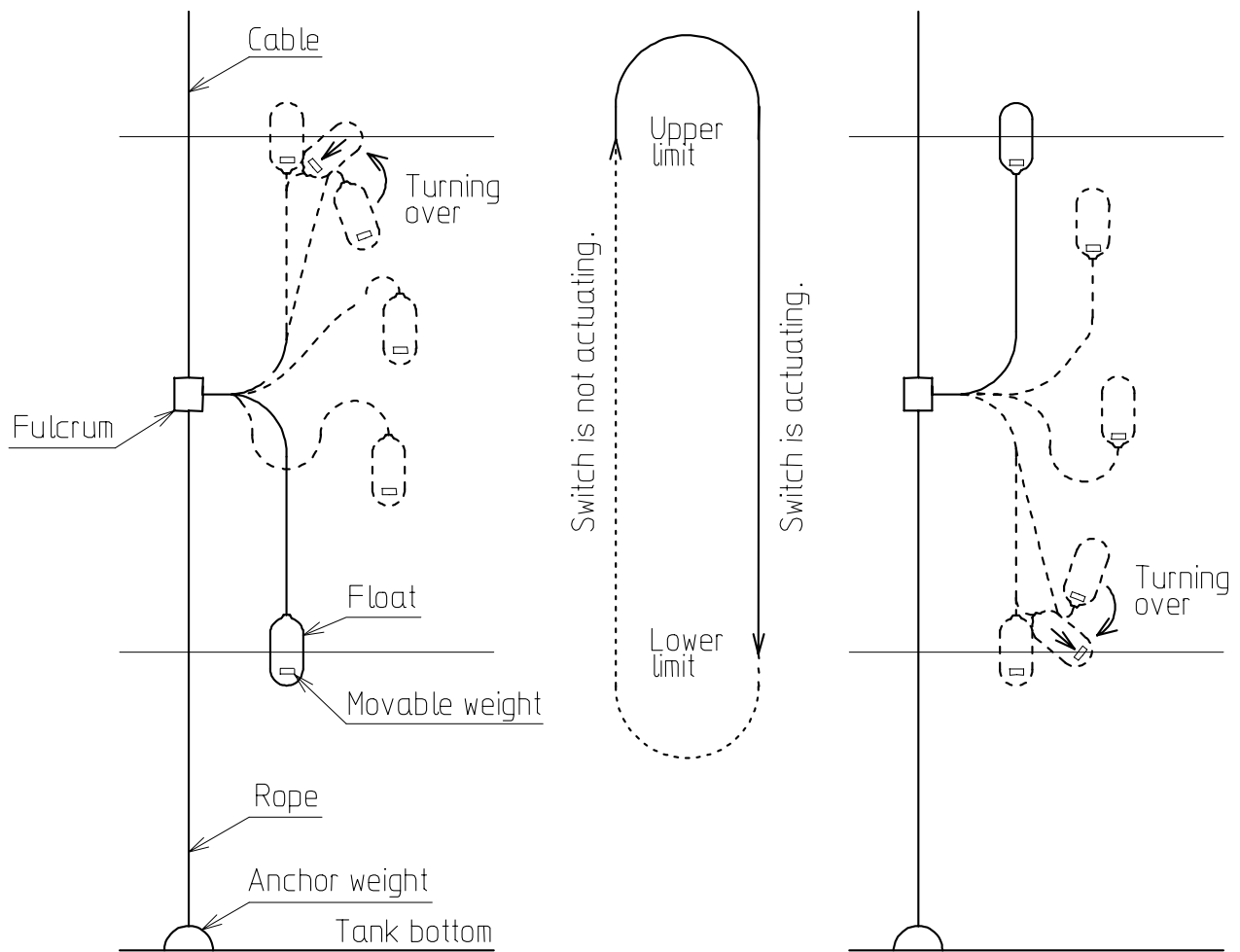

(1) At rising level

(2) At falling level

Fig. 4 Operating principle drawing

## 4. COMPONENT NAMES

### 4. 1 External parts

- ① Terminal box
- ② Flange
- ③ Eyebolt
- ④ Fulcrum
- ⑤ Cable
- ⑥ Float
- ⑦ Rope
- ⑧ Anchor weight
- ⑨ Cable inlet
- ⑩ Cable clip

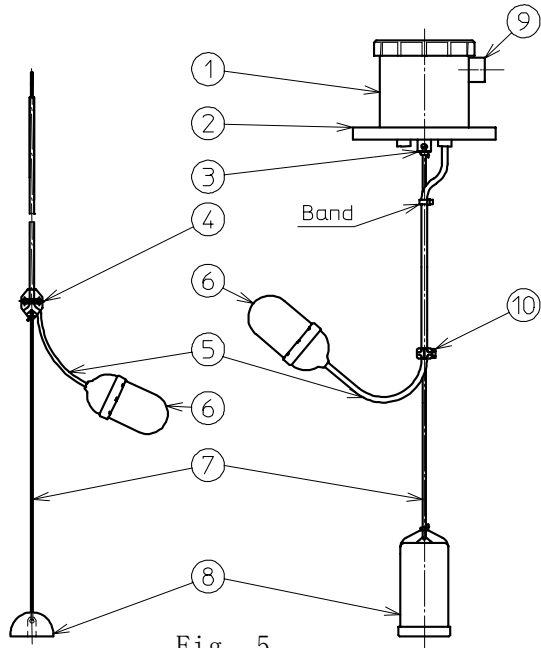

Fig. 5

### 4. 2 Terminal box internal parts

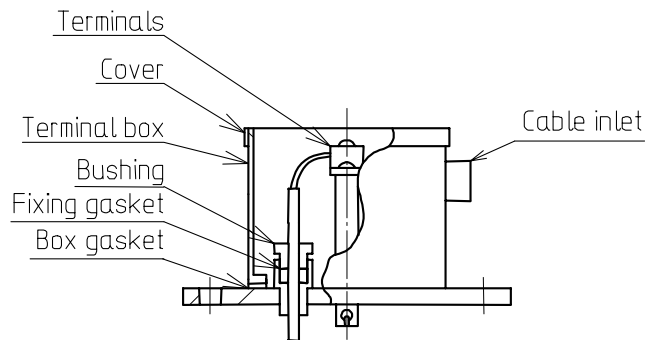

Fig. 6

## 5. INSTALLATION

### 5. 1 Unpacking

The Quick Float Model FQ series have been thoroughly inspected and carefully packed at the factory to prevent from damage during shipment.

When unpacking, exercise due care not to subject the instrument to mechanical shock. After unpacking, visually check the instrument exterior for damage.

NOTE the following points ;

- (1) Do not bend and pull the cable extremely during installation.
- (2) Make sure that the Quick Float is provided equipment according to ordering specification.
- (3) During installation, care must be taken not to damage cables with sharp objects.

## 5. 2 A s s e m b l y

Usually, the Quick Float is set specified measuring length before shipment. When not specified, each parts are packed severally. In that case, proceed to assemble as follows.

- (1) Fasten one end to the eyebolt on flange and the anchor weight to another end of rope according to depth of the tank.
- (2) Put in the cable into the flange from wetted side, and then put the fixing gasket and the bushing into the cable. (Refer to Fig. 7)

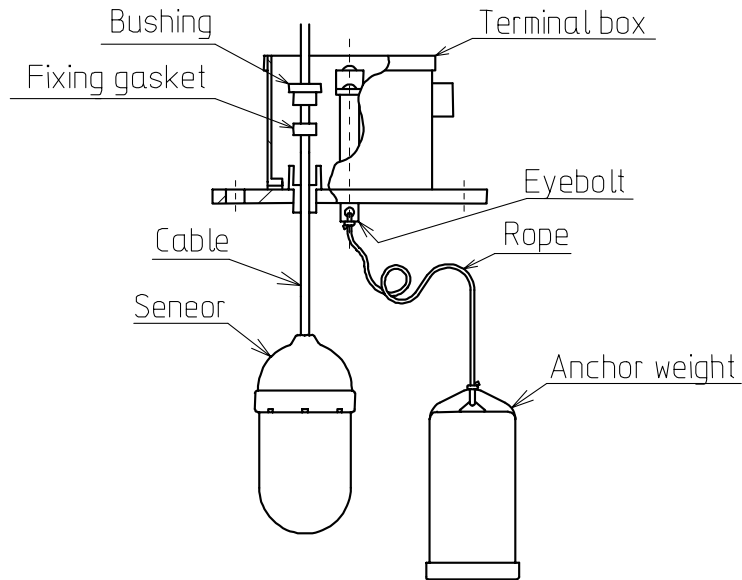

Fig. 7

- (3) Set the Quick Float on the rope with the rope clip.

- (a) In case of  
↑ ON setting.

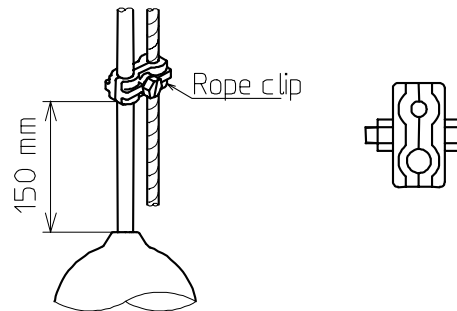

Fig. 8

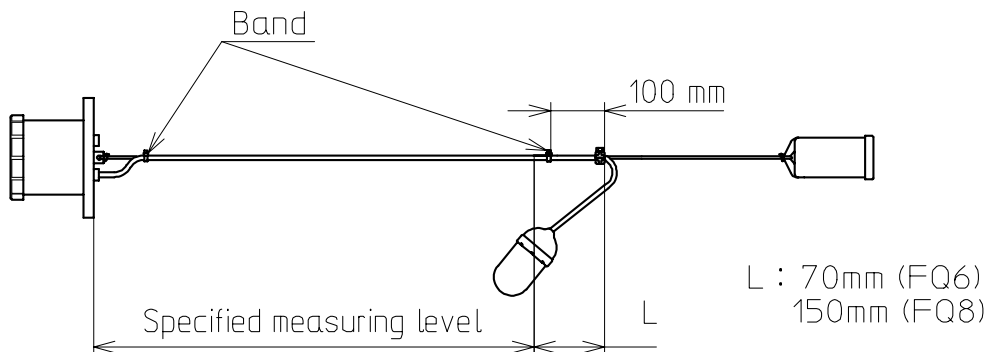
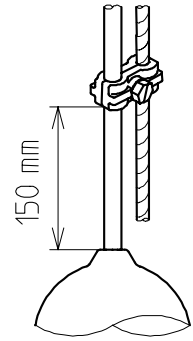
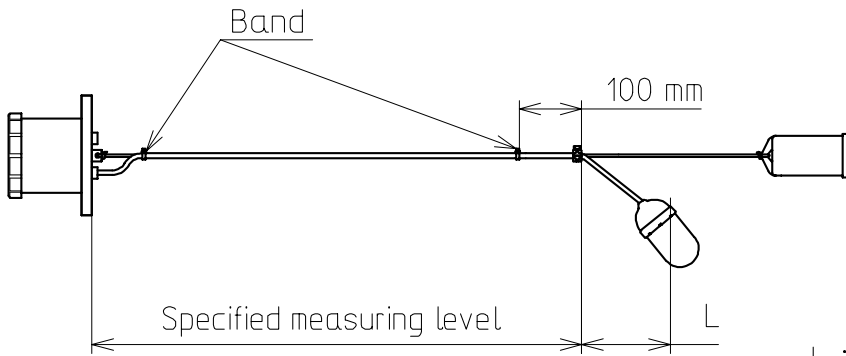

Fig. 9

(b) In case of ↓ OFF setting.



L : 70mm (FQ6)  
150mm (FQ8)

Fig. 10

(c) In case of upper and lower limit control.

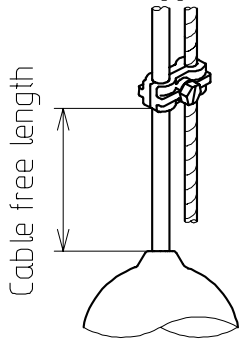

Set the Cable free length  
to Control width  $\times$  1/2

Fig. 11

NOTE the following points ;

- (1) Cable free length means length from bottom of float to clip set point.
- (2) Setting value of control width are 0.27 to 1 m at Model FQ66, 0.33 to 4 m at Model FQ88 and FQ88T.

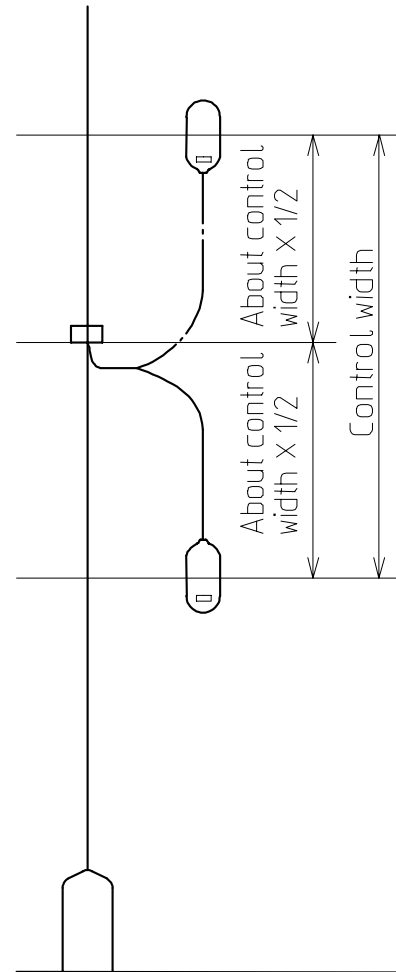

Fig. 12

- (3) Tighten the bushing not to loose and not to move the cable.
- (4) Bundle the cable and the rope with band.
- (5) Cut the useless part of cable and install compression terminals fitted to M3.5 screws to the end of lead wires.
- (6) Connect each lead wires to the terminals.  
Ex. In case of 3 points version, wiring is only  $\ell 1$ ,  $\ell 2$ , and  $\ell 3$ .

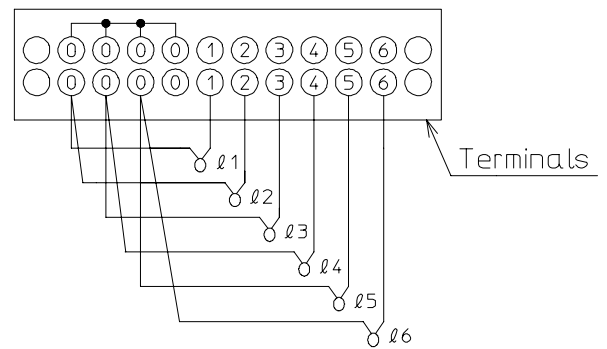

Fig. 13

### 5. 3 Installation location

This sensor should be installed in an area where the following conditions :

- (1) Sensor should be installed in an area where the ambient temperature is  $-10\text{ }^{\circ}\text{C}$  to  $50\text{ }^{\circ}\text{C}$ .
- (2) Low relative humidity and no exposure to moisture.
- (3) No corrosive gases (Such as  $\text{NH}_3$ ,  $\text{SO}_2$ ,  $\text{Cl}_2$  and so on).
- (4) No excessive vibration.
- (5) Provide ample space for maintenance / inspection.

### 5. 4 Installation method

This sensor is provided with JIS 10K 100A or another specified flange. Normally, it is installed on the mating flange which is compatible on the top of the tank.

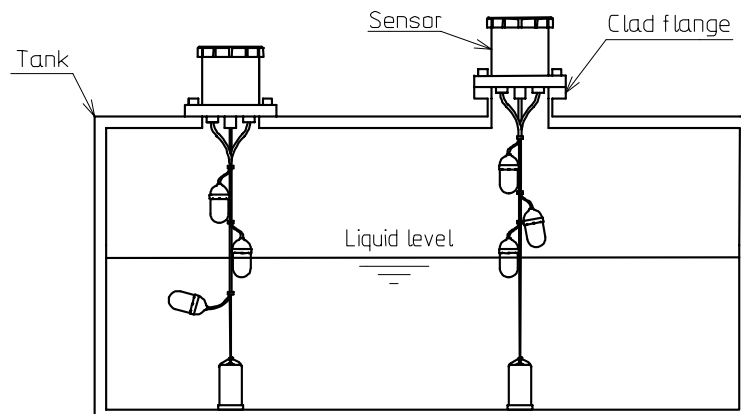

Fig. 14

NOTE the following points :

- (1) This unit should be located away from strong magnetic fields such as those produced by motors or solenoid valves.
- (2) Please use caution during installation. Hitting the Quick Float or pulling the cable may break the reed switches.
- (3) The size of the cable inlet is G3/4" .

There are two ways for connecting the sensor cable. One is fixing the cable with a cable gland. The other is connecting a conduit to the terminal box. In either case, an adequate sealing should be provided to prevent water or dust ingress into the terminal box through the sensor cable.

Secure the cable using sealing material for the conduit connection, or a proper tool when the gland is used, to protect the terminal box inside from dust or water.

When water or moisture comes into the terminal box from the conduit, use putty to fill the inside of the conduit.

## 6. WIRING

Fig. 15 denotes wiring of internal terminal box.

NOTE the following points ;

- (1) Install compression terminals fitted to M3.5 screw to the inner conductor.
- (2) The cable inlet must be properly fitted to preserve the protection category IP45 and to protect the sensor from rain, splashing water, and so on.
- (3) Reed switches are not designed for the direct starting of pumps, valves and alarms. They are susceptible to damage from electric surges. **DO NOT EXCEED THE CONTACT RATINGS.** Contacts should be wired to relays or similar devices.
- (4) We recommend the use of our relay unit Model RE7000, RE7500. The latching (holding relay) feature allows pumps, valves and other devices to be turned on at one level and off at another. It also contribute to safety since it allows lower voltage and smaller currents to be used with the Quick Float. For the relay unit Model RE7000, RE7500 refer to Instruction Manual.

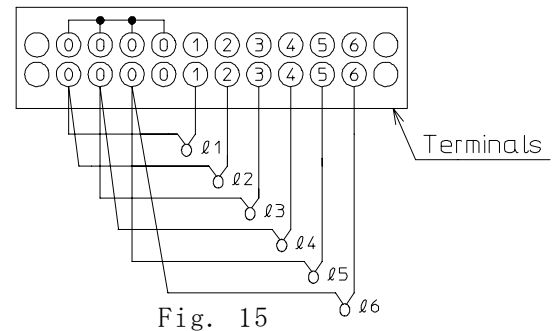

Fig. 15

### 6.1 Model RE relay unit

We recommend the use of our relay unit model RE. It is single level (alarm) and / or dual level (empty/fill control) relay.

The latching (holding relay) feature allows pumps, valves and other devices to be turned on at one level and off at another. It also contribute to safety since it allows lower voltage and smaller currents to be used with sensor.

#### · SINGLE LEVEL ALARM

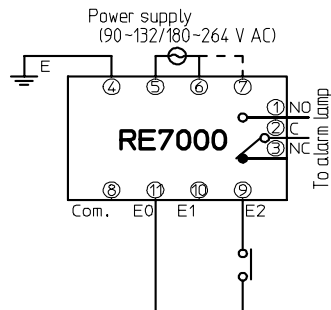

SELECT. SW. H. ON side : High alarm  
SELECT. SW. L. ON side : Low alarm

#### · DUAL LEVEL EMPTY/FILL CONTROL

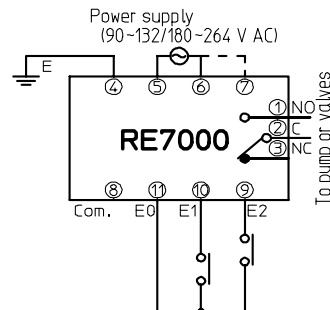

SELECT. SW. H. ON side : Filling control  
SELECT. SW. L. ON side : Emptying control

#### · SINGLE LEVEL ALARM

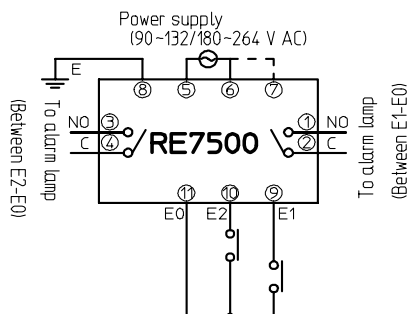

SELECT. SW. H. ON side : High alarm  
SELECT. SW. L. ON side : Low alarm

Fig. 16

For the relay unit Model RE, refer to Instruction Manual.

NOTE the following points:

- (1) Do not connect the plural relay unit to identical switch. Otherwise, the relay unit may be malfunction.

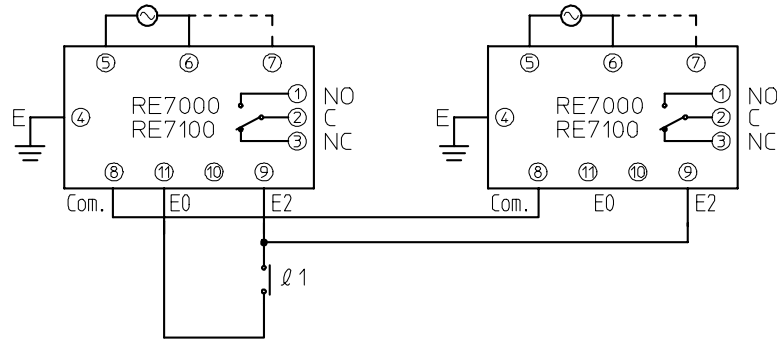

Fig. 17

- (2) Power supply must be connected in phase.

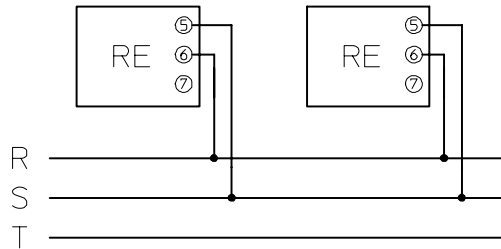

Fig. 18

- (3) To avoid malfunction, the wiring distance should be used within specifications. If the wiring distance exceed specifications, the relay unit may be malfunction by stray capacitance between cables or noise.

## 7. TECHNICAL NOTES

- (1) If the sensor is installed to oily wastewater or high concentration of acidic or alkaline wastewater, please periodically check the sensor is not deteriorated.
- (2) This sensor should be located away from excessive wave as inlet and outlet, or strong magnetic fields such as those produced by motors or solenoid valves.
- (3) Tighten terminals not to cause a trouble of miswiring.
- (4) Keep inside terminal box free from liquid, dust, metallic matter and so on
- (5) Do not throw the sensor, and do not drop that during installation.
- (6) Do not damage or splice the cable.

## 8. MAINTENANCE / INSPECTION

The following annual servicing tasks should be carried out on the sensor.

- (1) Visually check the sensor exterior for damage.
- (2) If sediment or other foreign matter are stained on wetted parts of sensor, keep wetted parts of sensor clean.
- (3) Connect ohmmeter or electronic buzzer to terminals, check the sensor actuation corresponding to float operation.

Re-install and re-wiring the sensor after maintenance / inspection in accordance with "5.4 Installation method" and "6. WIRING".

## 9. TROUBLE SHOOTING

### ⚠ WARNING

Use the following chart to troubleshoot the malfunctioning sensor. If your remedies are unsuccessful, ask Nohken for repair and replacement.

Table 2

Problems	Possible causes	Remedies
Liquids exceeds the actuation level, switch does not activate.	Miswiring.	Wire correctly.
	Sensor is not fixed on the rope.	Fix the rope clip.
	Float is damage.	Replace the sensor. ※1
	Reed switch is damage.	Replace the sensor. ※2
	Float does not move owing to cable hardening.	Replace the sensor. ※1
	Setting for improper length of the measuring sensor.	Set the specified measuring length
	Affected by deposit.	Clean the sensor.
Liquids does not exceed the actuation level, switch activate.	Miswiring.	Wire correctly.
	Float does not move owing to cable hardening.	Replace the sensor. ※1
	Reed switch is damage.	Replace the sensor.
	Setting for improper length of the measuring sensor.	Set the specified measuring length
Switch chatter.	Miswiring between sensor and relay.	Reconnect wiring correctly.

※1 There are some liquids that are not compatible with PVC or ABS.

In assessing corrosion, key factors are concentration, liquid's temperature and the amount of time the sensor immersed. Please check them.

※2 Reed switch was damaged over current by miswiring, re-wire correctly.

If above remedies are unsuccessful, ask NOHKEN INC. to repair and replace.



# NOHKEN INC.

HEAD OFFICE : 15-29, Hiroshiba-cho, Suita-city, Osaka 564-0052, Japan.  
TEL:06-6386-8141 FAX:06-6386-8140

TOKYO BRANCH OFFICE : 67, Kandasakumagashi, Chiyoda-ku, Tokyo 101-0026, Japan.  
TEL:03-5835-3311 FAX:03-5835-3316

NAGOYA OFFICE : 3-10-17, Uchiyama, Chikusa-ku, Nagoya-city, Aichi 464-0075, Japan.  
TEL:052-731-5751 FAX:052-731-5780

KYUSHU OFFICE : 14-1, 2-chome, Asano, Kokurakita-ku, Kitakyushu-city, Fukuoka 802-0001, Japan.  
TEL:093-521-9830 FAX:093-521-9834