

I N S T R U C T I O N   M A N U A L  
F O R

M O N I T O R   U N I T

M O D E L :   P S 7 0 0 0

Revision △   Jun. 03, 2002

Issued   Sep. 25, 1999



**NOHKEN INC.**



---

# MUST BE READ BEFORE USING





- This manual is for standard specifications. Read the other manuals for explosion-proof specifications.
- This manual describes the handling, inspection and adjustment of the sensor. Read and understand this manual before installation.
- Any documents and/or directions from Nohken and the agents aside from this manual shall be preceded.
- Save this manual to refer when you need.
- If you have any questions or comments about this manual and/or the sensor, ask Nohken's sales office written on the front cover.

Signal words in this manual means as follows:



 <b>CAUTION</b>	Indicates an potentially hazardous situation which, if not avoided, may result in minor or moderate injury.
 <b>NOTE</b>	Indicates exceptional cases and attention for handling of sensors.

	Indicates prohibition. The explanation with this manual should always be followed.
	Indicates directions. The explanation with this manual should always be followed.

▲ CAUTIONS

<p>• Since this sensor is not an explosion-proof construction, do not use where flammable gas, explosive gas or the vapor exists. Otherwise, explosion the gases and/or the vapor may cause serious disasters. Use explosion-proof sensors at hazard areas.</p>	
<p>• Do not modify or disassemble the sensor. Otherwise, the sensor may be damaged,</p>	
<p>• Operating test shall be conducted before practical use. If malfunction occurs and the accident is predicted, the remedy shall be administrated by using another sensor with different operating principle in parallel.</p>	
<p>• To prevent from electric shocks such as lightning and the static electricity, provide conductor or the surge absorber. Otherwise, the sensor may cause malfunction, damage, ignition, electric shock and injury.</p>	
<p>• <u>When connecting inductive load or the lamp load to the relay output contact.</u> To prevent overvoltage and overcurrent, provide a protective circuit to the load. Otherwise, the contact may be damaged.</p>	

▲ NOTES

<p>• Do not give strong shocks to the sensor. Dropping, throwing, striking and dragging the sensor, for example, are to cause strong shocks and damage the sensor.</p>	
<p>• The specifications such as ambient temperature, maximum voltage and the power rating shall meet the conditions. Otherwise, the sensor may cause malfunction, damage, ignition, electric shock and injury. Read and check the clause of specification in the manual or specification sheets.</p>	
<p>• Operating test shall be conducted before practical use. If malfunction occurs and the accident is predicted, the remedy shall be administrated by using another sensor with different operating principle in parallel.</p>	

⚠ **NOTES**

• To prevent from electric shocks such as lightning and the static electricity, provide conductor or the surge absorber. Otherwise, the sensor may cause malfunction, damage, ignition, electric shock and injury.



• When connecting inductive load or the lamp load to the relay output contact.

To prevent overvoltage and overcurrent, provide a protective circuit to the load. Otherwise, the contact may be damaged.



## INTRODUCTION

- A. This manual specifies standard specifications of this product. Some specifications may be different from your product if you order the custom-made product.
- B. A variety of specifications are available to meet your process conditions, such as installation conditions, chemical compatibility, and so on. We are glad to offer suggestions to assist your decision.
- C. If you have any questions or comments for the contents of this manual, ask Nohken's sales office written on the front cover.
- D. Nohken Inc. pursues a policy of continuing improvement in design and performance of this product. We will supply the alternative parts or complete new products required to repair or replacement.
- E. Specifications are subject to change without any obligation on the part of the manufacturer.

# WARRANTY & DISCLAIMER

- A. Nohken Inc. warrants this product against defects in design, material and workmanship for a period of 1 (one) year from the date of original factory shipment.
- B. If defects occurs during the above-mentioned warranty period, Nohken will, at its option, replace or recondition the product without charge. This shall constitute the exclusive remedy for breach of warranty.
- C. Nohken Inc. makes no warranty with respect to:
  - C-a Failure not to comply with instructions of this manual.
  - C-b Failure or damage due to improper installation, wiring, operation, maintenance, inspection and storing.
  - C-c Product which has been in any way repaired, altered or tampered with by others.
  - C-d Product repaired or modified by using undesignated parts, subassemblies and materials.
  - C-e Direct incidental or consequential damages or losses or expenses resulting from any defective product or the use of any product.
  - C-f Objective of the sensor is clearly specified in chapter 1, PURPOSE OF USE.
  - C-g Inevitable accident such as acts of God, force majeure, radioactive contamination and so on.

THIS WARRANTY IS IN LIEU OF AND EXCLUDES ALL OTHER WARRANTIES OF MERCHANTABILITY OR FITNESS FOR A PARTICULAR PURPOSE.

# NOTES TO USERS

First of all, it is essential that this manual shall be read and understood before installation and start-up of the Level Presetter. This manual covers instruction for the installation, wiring and adjustment.

## TABLE OF CONTENTS

MUST BE READ BEFORE USING  
INTRODUCTION  
WARRANTY & DISCLAIMER

1. PURPOSE OF USE	...Page 2	6. WIRING	...Page 5
2. SPECIFICATIONS	...Page 2	7. ALARM SETTING	...Page 6
2.1 Model		7.1 Start-up	
2.2 Standard specifications		7.2 Alarm signal setting	
3. OPERATING PRINCIPLE	...Page 3	7.3 Adjustment method	
4. COMPONENT NAMES	...Page 3	8. INSPECTION AND MAINTENANCE	...Page 6
5. INSTALLATION	...Page 4	9. TROUBLESHOOTING	...Page 7
5.1 Unpacking			
5.2 Installation location			
5.3 Installation method			

# 1. PURPOSE OF USE

The Level Presetter Model P S 7 0 0 0 converts several analog signal into output alarm contacts to control high and low alarm.

# 2. SPECIFICATIONS

## 2.1 Model

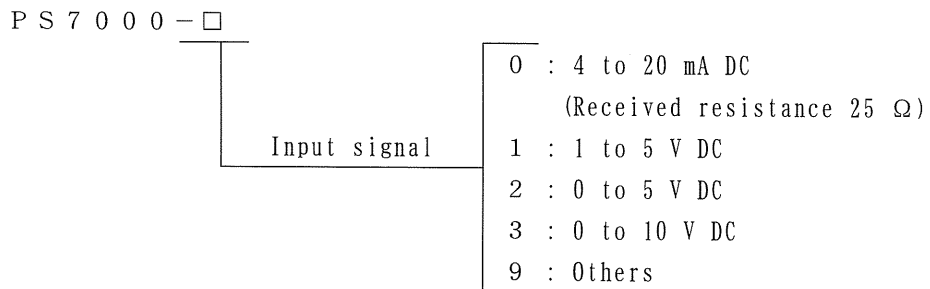

## 2.2 Standard specifications

### 2.2.1 Operation characteristics

- |                                |   |
|--------------------------------|---|
| (1) Indication of Alarm signal | : LED (Red)   |
| (2) Accuracy versus setting    | : ± 0.5 %F. S.  |
| (3) Hysteresis                 | : 0.5 to 1.0 %F. S.                                   |
| (4) Number of set points       | : High alarm 1 S. P. D. T.<br>Low alarm 1 S. P. D. T. |
| (5) Setting range              | : Adjustable setting with Full span                   |

### 2.2.2 Electrical characteristics

- |                              |  |
|------------------------------|--|
| (1) Power supply             | : 90 to 132 / 180 to 264 V AC,<br>47.5 to 63 Hz              |
| (2) Power consumption        | : 2 VA Max.  |
| (3) Input signal             | : Refer to "Model pattern"                                   |
| (4) Output signal of Contact | : Relay contact 250 V 7 A AC<br>(Resistive load) 30 V 7 A DC |

### 2.2.3 Environmental condition

- |                              |                                |
|------------------------------|--------------------------------|
| (1) Working temperature      | : - 20 to 50 °C                |
| (2) Preservation temperature | : - 20 to 70 °C                |
| (3) Working humidity         | : 80 %RH Max. (Get rid of dew) |

### 2.2.4 Physical

- |                         |   |
|-------------------------|---|
| (1) Dimension           | : W 50 × H 84 × D 109                                     |
| (2) Installation method | : Plug-in mounting  |
| (3) Socket              | : Optional part (OMRON made<br>Model 11PFA or equivalent) |
| (4) Mass                | : Approx. 350 g (Except socket)                           |

### 3. OPERATING PRINCIPLE

The Level Presetter converts several input signal into outputs alarm contacts. The Level Presetter has independent of two alarm contacts, one for high alarm signals and one for low alarm contacts.

High alarm contact actuates when input signal exceed pre-set alarm setting value, and low alarm contact actuates when input signal is below pre-set alarm setting value.

In case of relay actuating, relay operation indicator lamps light up.

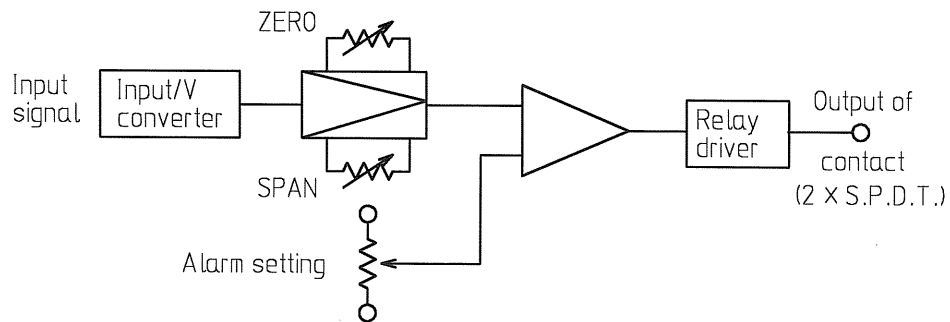

Fig. 1 Drawing of operating principle

### 4. COMPONENT NAMES

- ① Power indication lamp :  
This lamp lights up, when the unit is turned on the power.
- ② Relay actuation lamp for high alarm :  
This lamp lights up, when input signal exceed the setting value, and the relay actuates.
- ③ HIGH VR :  
Alarm setting trimmer for high alarm.
- ④ Relay actuation lamp for low alarm :  
This lamp lights up, when input signal exceed the setting value, and the relay actuates.
- ⑤ LOW VR :  
Alarm setting trimmer for high alarm.
- ⑥ HIGH monitor terminal :  
Monitor terminal for high alarm setting.
- ⑦ LOW volume :  
Monitor terminal for high alarm setting :
- ⑧ Common terminal :  
Common terminal of ⑥, ⑦ terminals.

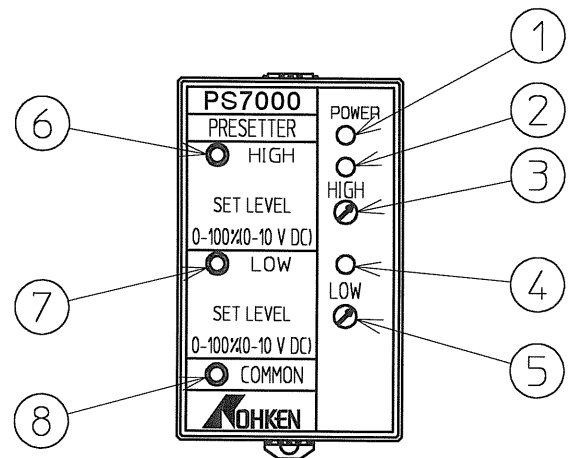

Fig. 2 Front panel

※ VR : Variable Resistor



# 5. INSTALLATION

## 5.1 Unpacking

The Level Presetter has been thoroughly inspected and carefully packed at the factory to prevent from damage during shipment. When unpacking, exercise due care not to subject the instrument to mechanical shock.

After unpacking, visually check the instrument exterior for damage.

## 5.2 Installation location

The Level Presetter has should be installed in an area where the following condition ;

- (1) Provide ample space for maintenance / inspection.
- (2) Low relative humidity and no exposure to moisture.
- (3) No corrosive gases(NH<sub>3</sub>, Cl<sub>2</sub>, SO<sub>2</sub> and so on).
- (4) No excessive vibration.

## 5.3 Installation method

**NOTE :** The Level Presetter should be installed in an area where the ambient temperature is -20 °C to 50 °C.

**CAUTION :** Provide appropriate means to guard against moisture if the temperature is low. Otherwise, the Level Presetter may be damage.

Proceed as follows : (See Fig. 3)

- (1) Fix the socket(optional part) on mounting board directly with M4 screws (2 × φ4.5 holes, Pitch 40), or insert that into DIN rail(34 mm).
- (2) Put in the Level Presetter into the socket.

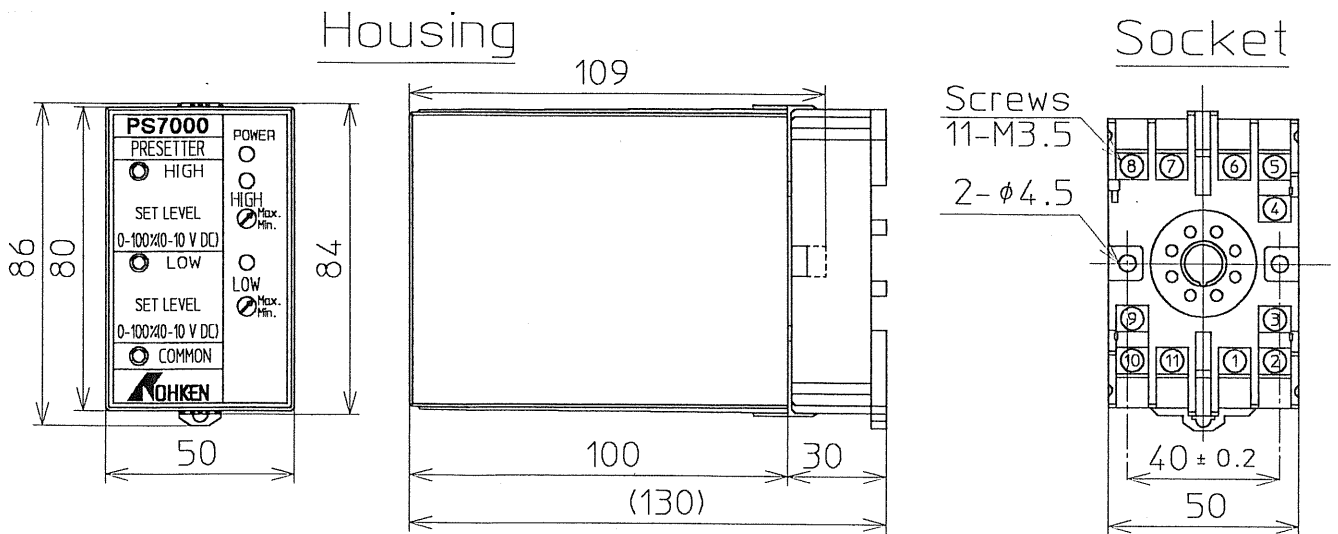

Fig. 3 Outline drawing of Model PS7000

# 6. WIRING

Proceed as follows :

- (1) Connect the cables to terminals as shown in Fig. 4.

**CAUTION** : Make sure that the power supply is turned off.

- (2) Double-check wiring for correctness.

**NOTE** the following points :

- (1) The wires for the relay and power supply should be used shielded cable on condition that a wire is diameter between  $0.3 \text{ mm}^2$  and  $1.25 \text{ mm}^2$ .

**WARNING!**

⊙ To avoid injury, connect the power supply to the Level Presetter after wiring another device.

- (2) Make sure that the shield cables are one-point grounded.

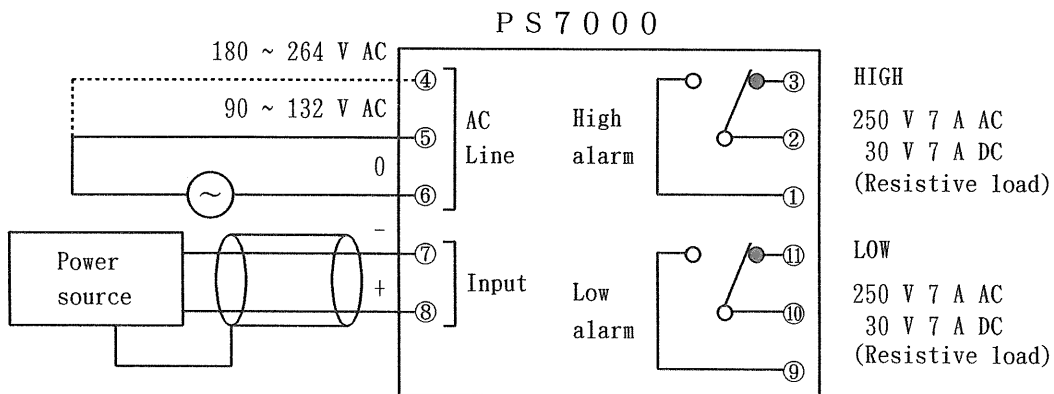

Fig. 4 Wiring

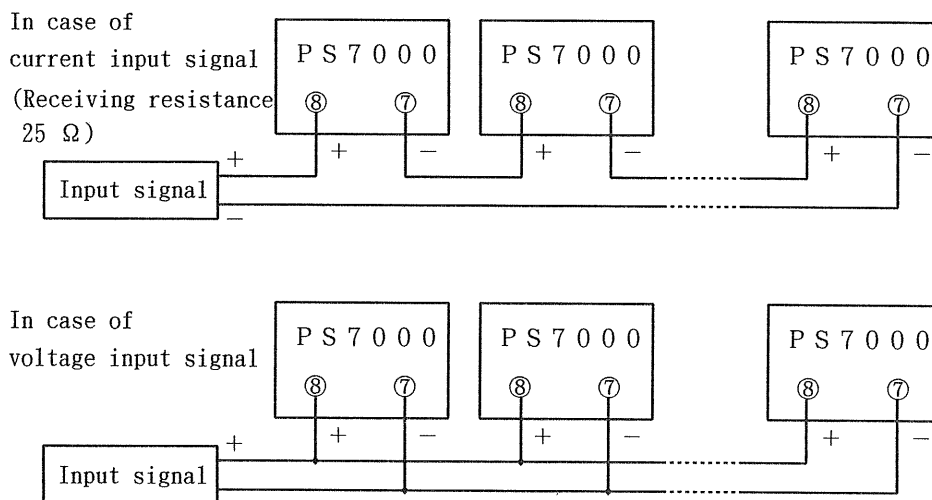

Fig. 5 Plural connection of Model PS7000

## 7. ALARM SETTING

### 7. 1 S t a r t - u p

Proceed as follows :

- (1) Make sure that there are no miswiring.

CAUTION : Supply voltage must match the terminals indicated on the front panel. Incorrect voltage miswiring will damage the Level Presetter.

- (2) Turn on the power.
- (3) Check the "power indication lamp" is ON, indicate power on. See Fig. 3.
- (4) Check the output of contact actuation correctly.

NOTE : When not otherwise specified, alarm setting value have set low alarm - 20 % · High alarm - 80 % before shipment,

### 7. 2 A l a r m s i g n a l s e t t i n g

Proceed as follows : (Refer to Fig. 2)

- (1) Connect digital voltmeter between monitor terminal(+) and common terminal(-).

NOTE : In case of high alarm, connect between HIGH monitor terminal(+) and common terminal(-). In case of low alarm, connect between LOW monitor terminal(+) and common terminal(-).

- (2) Turn the setting trimmer(HIGH VR or LOW VR), and set alarm setting value with voltmeter.

NOTE : Monitor voltage denotes 0 to 10 V DC correspondence with input signal 0 to 100 %.

## 8. INSPECTION AND MAINTENANCE

We recommend to carry out maintenance and inspection at a time in a year.

If alarm setting value are wrong, wait for about 10 minutes after turning on the power and then carry out re-adjustment according to "7.ALARM SETTING".

## 9. TROUBLESHOOTING

⚠ CAUTION

Use the following chart to troubleshoot the malfunctioning sensor.  
If your remedies are unsuccessful, ask Nohken for repair and replacement.

Problems	Causes	Solutions
Power indication lamp does not light up.	Power is supply is not connected.	Connect the power.
Relay does not actuate correctly.	Power is supply is not connected.	Connect the power.
	Input line is short-circuit in the wire between input signal and the Level Presetter.	Check parts of input and re-wiring
	Output line is breaking of wire.	Check parts of output line, and re-wiring.
	Alarm setting are incorrect.	Set correctly reference to "7.2 Alarm signal setting".
	Excess input signal	Regulate the specification

# NOHKEN INC.

HEAD OFFICE : 15-29,Hiroshiba-cho,Suita-city,Osaka 564-0052,Japan.

TEL:06-6386-8141 FAX:06-6386-8140

TOKYO BRANCH OFFICE : 67,Kandasakumagashi,Chiyoda-ku,Tokyo 101-0026,Japan.

TEL:03-5835-3311 FAX:03-5835-3316

NAGOYA OFFICE : 3-10-17,Uchiyama,Chikusa-ku,Nagoya-city,Aichi 464-0075,Japan.

TEL:052-731-5751 FAX:052-731-5780

KYUSHU OFFICE : 14-1,2-chome,Asano,Kokurakita-ku,Kitakyushu-city,Fukuoka 802-0001,Japan.

TEL:093-521-9830 FAX:093-521-9834